CHAPTER 9

DC MOTORS AND GENERATORS

DC motors are dc machines used as motors, and dc generators are dc machines used as generators. As noted in Chapter 8, the same physical machine can operate as either a motor or a generator—it is simply a question of the direction of the power flow through it. This chapter will examine the different types of dc motors that can be made and explain the advantages and disadvantages of each. It will include a discussion of dc motor starting and solid-state controls. Finally, the chapter will conclude with a discussion of dc generators.

9.1 INTRODUCTION TO DC MOTORS

The earliest power systems in the United States were dc systems, but by the 1890s ac power systems were clearly winning out over dc systems. Despite this fact, dc motors continued to be a significant fraction of the machinery purchased each year through the 1960s (that fraction has declined in the last 40 years). Why were dc motors so common, when dc power systems themselves were fairly rare?

There were several reasons for the continued popularity of dc motors. One was that dc power systems are still common in cars, trucks, and aircraft. When a vehicle has a dc power system, it makes sense to consider using dc motors. Another application for dc motors was a situation in which wide variations in speed are needed. Before the widespread use of power electronic rectifier-inverters, dc motors were unexcelled in speed control applications. Even if no dc power source were available, solid-state rectifier and chopper circuits were used to create the necessary dc power, and dc motors were used to provide the desired speed control.

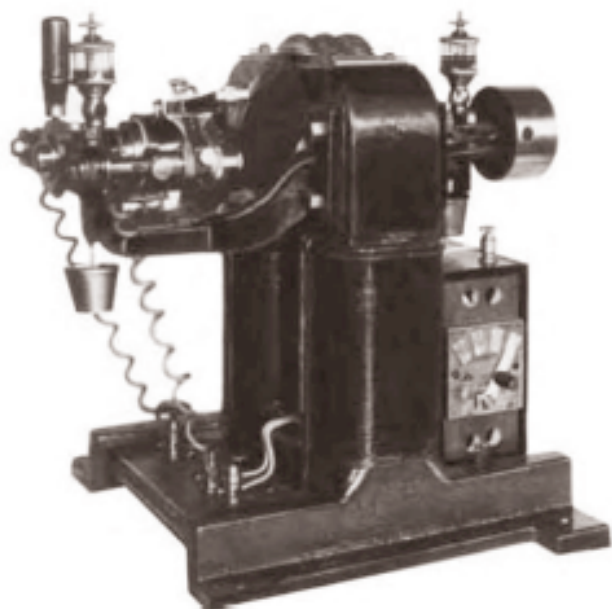

(a)

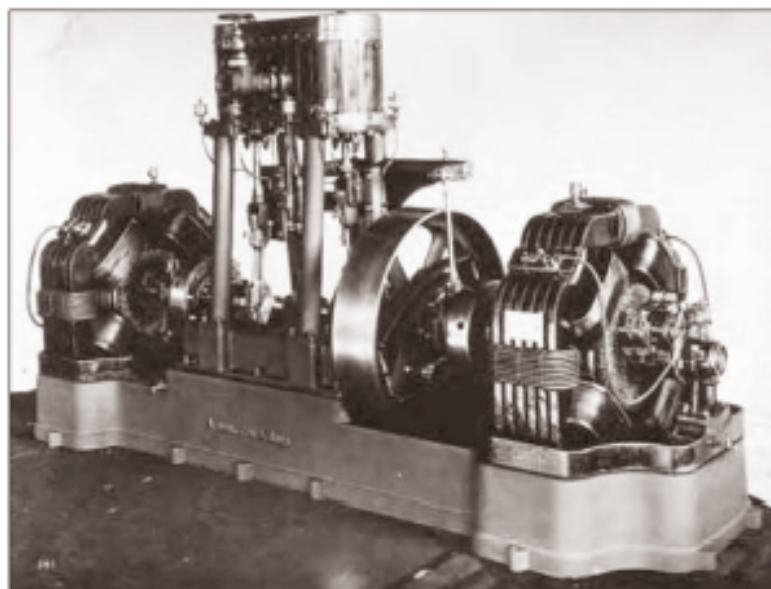

(b)

FIGURE 9-1

Early dc motors. (a) A very early dc motor built by Elihu Thompson in 1886. It was rated at about ½ hp. (Courtesy of General Electric Company.) (b) A larger four-pole dc motor from about the turn of the century. Notice the handle for shifting the brushes to the neutral plane. (Courtesy of General Electric Company.)

(Today, induction motors with solid-state drive packages are the preferred choice over dc motors for most speed control applications. However, there are still some applications where dc motors are preferred.)

DC motors are often compared by their speed regulations. The *speed regulation* (SR) of a motor is defined by

$$SR = \frac{\omega_{nl} - \omega_{fl}}{\omega_{fl}} \times 100\% \tag{9-1}$$

$$\text{SR} = \frac{n_{nl} - n_{fl}}{n_{fl}} \times 100\% \quad (9-2)$$

It is a rough measure of the shape of a motor's torque–speed characteristic—a positive speed regulation means that a motor's speed drops with increasing load, and a negative speed regulation means a motor's speed increases with increasing load. The magnitude of the speed regulation tells approximately how steep the slope of the torque–speed curve is.

DC motors are, of course, driven from a dc power supply. Unless otherwise specified, *the input voltage to a dc motor is assumed to be constant*, because that assumption simplifies the analysis of motors and the comparison between different types of motors.

There are five major types of dc motors in general use:

1. The separately excited dc motor
2. The shunt dc motor
3. The permanent-magnet dc motor
4. The series dc motor
5. The compounded dc motor

Each of these types will be examined in turn.

9.2 THE EQUIVALENT CIRCUIT OF A DC MOTOR

The equivalent circuit of a dc motor is shown in Figure 9–2. In this figure, the armature circuit is represented by an ideal voltage source E_A and a resistor R_A . This representation is really the Thevenin equivalent of the entire rotor structure, including rotor coils, interpoles, and compensating windings, if present. The brush voltage drop is represented by a small battery V_{brush} opposing the direction of current flow in the machine. The field coils, which produce the magnetic flux in the generator, are represented by inductor L_F and resistor R_F . The separate resistor R_{adj} represents an external variable resistor used to control the amount of current in the field circuit.

There are a few variations and simplifications of this basic equivalent circuit. The brush drop voltage is often only a very tiny fraction of the generated voltage in a machine. Therefore, in cases where it is not too critical, the brush drop voltage may be left out or approximately included in the value of R_A . Also, the internal resistance of the field coils is sometimes lumped together with the variable resistor, and the total is called R_F (see Figure 9–2b). A third variation is that some generators have more than one field coil, all of which will appear on the equivalent circuit.

The internal generated voltage in this machine is given by the equation

$$E_A = K\phi\omega \quad (8-38)$$

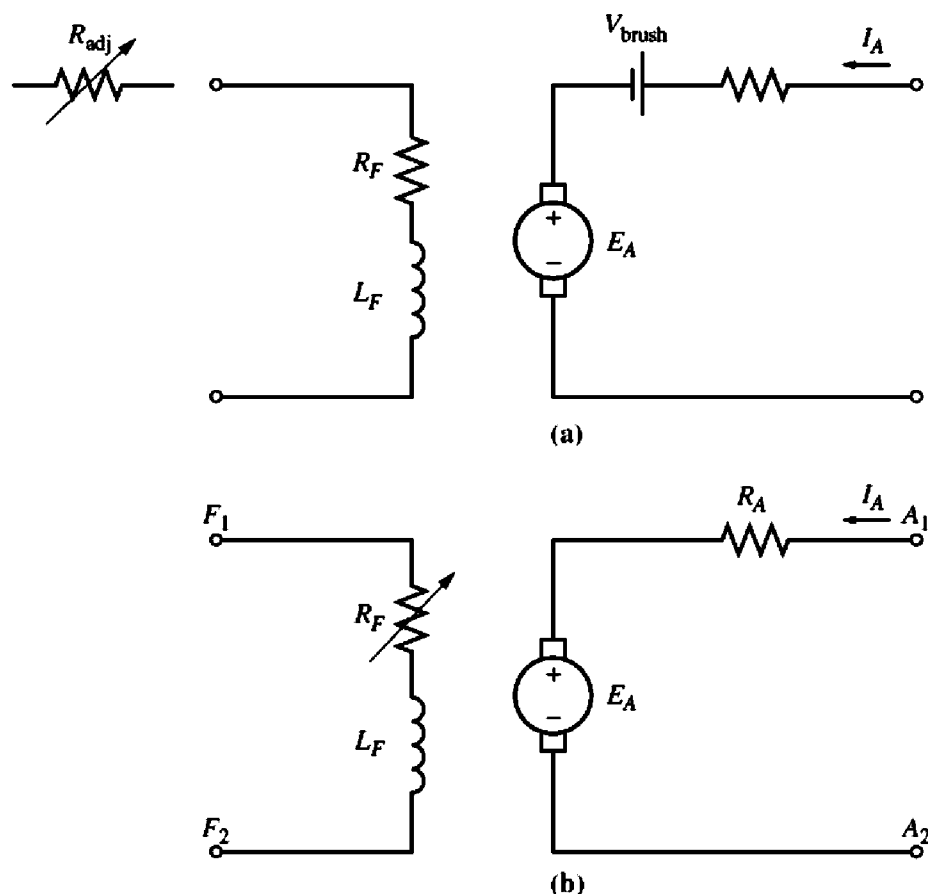

FIGURE 9-2

(a) The equivalent circuit of a dc motor. (b) A simplified equivalent circuit eliminating the brush voltage drop and combining R_{adj} with the field resistance.

and the induced torque developed by the machine is given by

$$\tau_{ind} = K\phi I_A \quad (8-49)$$

These two equations, the Kirchhoff's voltage law equation of the armature circuit and the machine's magnetization curve, are all the tools necessary to analyze the behavior and performance of a dc motor.

9.3 THE MAGNETIZATION CURVE OF A DC MACHINE

The internal generated voltage E_A of a dc motor or generator is given by Equation (8-38):

$$E_A = K\phi\omega \quad (8-38)$$

Therefore, E_A is directly proportional to the flux in the machine and the speed of rotation of the machine. How is the internal generated voltage related to the field current in the machine?

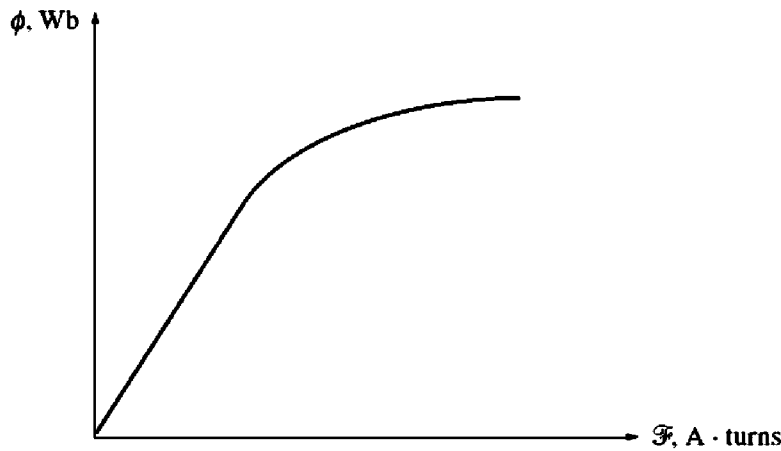

FIGURE 9-3
The magnetization curve of a ferromagnetic material (ϕ versus \mathcal{F}).

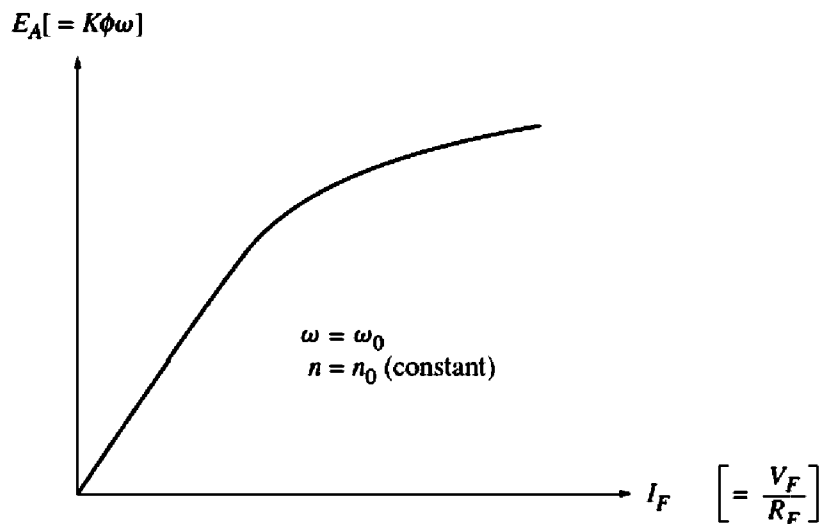

FIGURE 9-4
The magnetization curve of a dc machine expressed as a plot of E_A versus I_F , for a fixed speed ω_0 .

The field current in a dc machine produces a field magnetomotive force given by $\mathcal{F} = N_F I_F$. This magnetomotive force produces a flux in the machine in accordance with its magnetization curve (Figure 9-3). Since the field current is directly proportional to the magnetomotive force and since E_A is directly proportional to the flux, it is customary to present the magnetization curve as a plot of E_A versus field current for a given speed ω_0 (Figure 9-4).

It is worth noting here that, to get the maximum possible power per pound of weight out of a machine, most motors and generators are designed to operate near the saturation point on the magnetization curve (at the knee of the curve). This implies that a fairly large increase in field current is often necessary to get a small increase in E_A when operation is near full load.

The dc machine magnetization curves used in this book are also available in electronic form to simplify the solution of problems by MATLAB. Each magnetization curve is stored in a separate MAT file. Each MAT file contains three

variables: i_f values, containing the values of the field current; e_a values, containing the corresponding values of E_A ; and n_0 , containing the speed at which the magnetization curve was measured in units of revolutions per minute.

9.4 SEPARATELY EXCITED AND SHUNT DC MOTORS

The equivalent circuit of a separately excited dc motor is shown in Figure 9-5a, and the equivalent circuit of a shunt dc motor is shown in Figure 9-5b. A separately excited dc motor is a motor whose field circuit is supplied from a separate

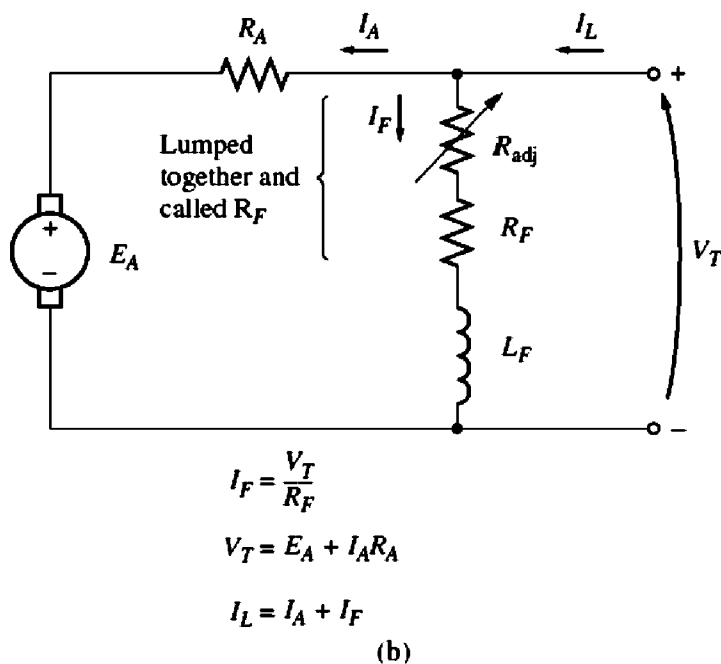
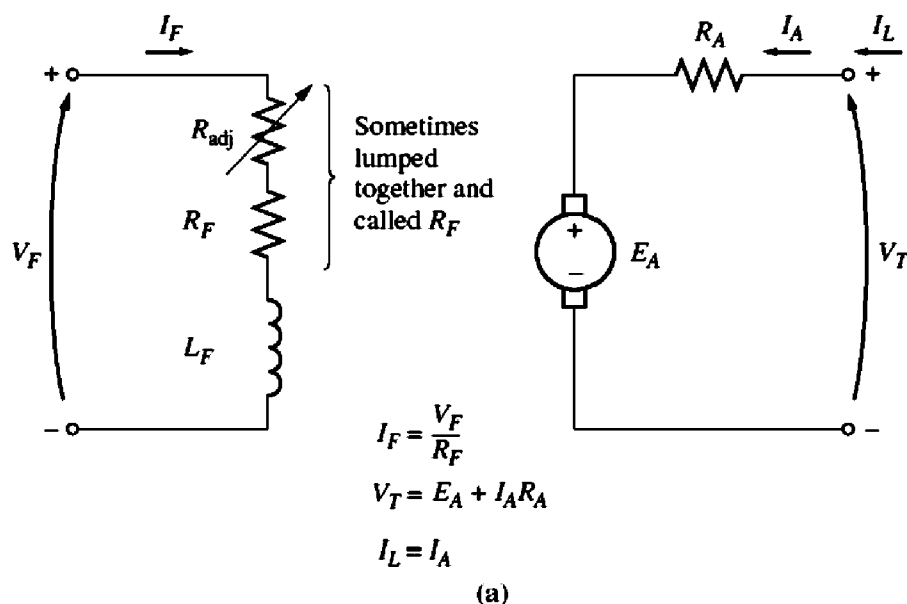

FIGURE 9-5

(a) The equivalent circuit of a separately excited dc motor. (b) The equivalent circuit of a shunt dc motor.

constant-voltage power supply, while a shunt dc motor is a motor whose field circuit gets its power directly across the armature terminals of the motor. When the supply voltage to a motor is assumed constant, there is no practical difference in behavior between these two machines. Unless otherwise specified, whenever the behavior of a shunt motor is described, the separately excited motor is included, too.

The Kirchhoff's voltage law (KVL) equation for the armature circuit of these motors is

$$\boxed{V_T = E_A + I_A R_A} \quad (9-3)$$

The Terminal Characteristic of a Shunt DC Motor

A terminal characteristic of a machine is a plot of the machine's output quantities versus each other. For a motor, the output quantities are shaft torque and speed, so the terminal characteristic of a motor is a plot of its output *torque versus speed*.

How does a shunt dc motor respond to a load? Suppose that the load on the shaft of a shunt motor is increased. Then the load torque τ_{load} will exceed the induced torque τ_{ind} in the machine, and the motor will start to slow down. When the motor slows down, its internal generated voltage drops ($E_A = K\phi\omega \downarrow$), so the armature current in the motor $I_A = (V_T - E_A \downarrow)/R_A$ increases. As the armature current rises, the induced torque in the motor increases ($\tau_{\text{ind}} = K\phi I_A \uparrow$), and finally the induced torque will equal the load torque at a lower mechanical speed of rotation ω .

The output characteristic of a shunt dc motor can be derived from the induced voltage and torque equations of the motor plus Kirchhoff's voltage law. (KVL) The KVL equation for a shunt motor is

$$V_T = E_A + I_A R_A \quad (9-3)$$

The induced voltage $E_A = K\phi\omega$, so

$$V_T = K\phi\omega + I_A R_A \quad (9-4)$$

Since $\tau_{\text{ind}} = K\phi I_A$, current I_A can be expressed as

$$I_A = \frac{\tau_{\text{ind}}}{K\phi} \quad (9-5)$$

Combining Equations (9-4) and (9-5) produces

$$V_T = K\phi\omega + \frac{\tau_{\text{ind}}}{K\phi} R_A \quad (9-6)$$

Finally, solving for the motor's speed yields

$$\boxed{\omega = \frac{V_T}{K\phi} - \frac{R_A}{(K\phi)^2} \tau_{\text{ind}}} \quad (9-7)$$

This equation is just a straight line with a negative slope. The resulting torque-speed characteristic of a shunt dc motor is shown in Figure 9-6a.

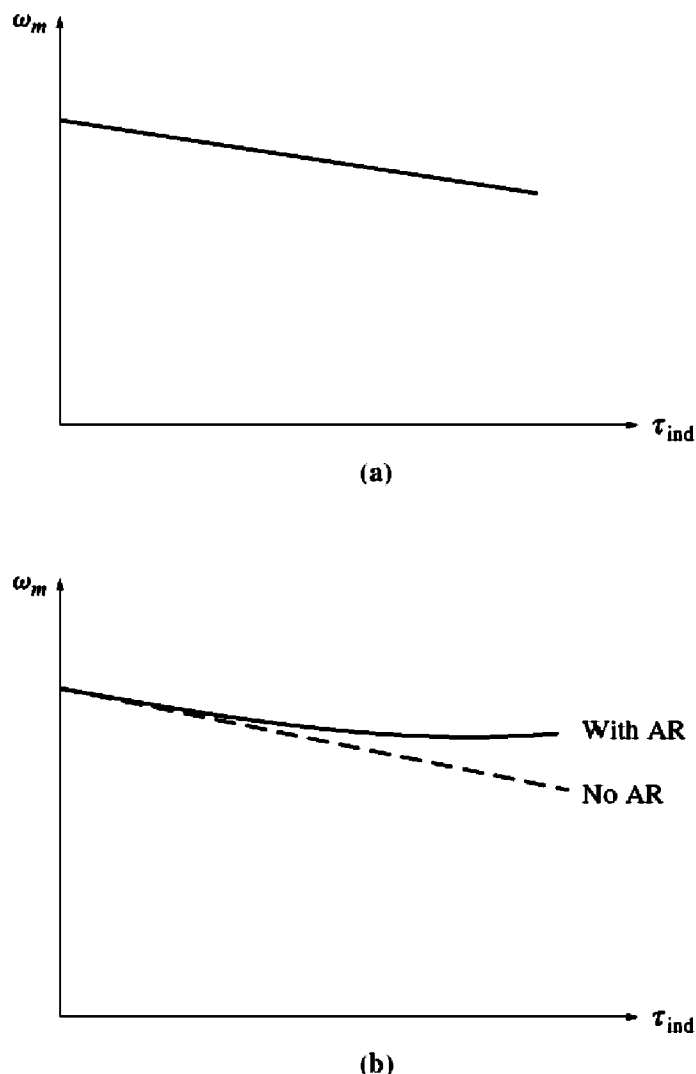
**FIGURE 9-6**

(a) Torque–speed characteristic of a shunt or separately excited dc motor with compensating windings to eliminate armature reaction. (b) Torque–speed characteristic of the motor with armature reaction present.

It is important to realize that, in order for the speed of the motor to vary linearly with torque, the other terms in this expression must be constant as the load changes. The terminal voltage supplied by the dc power source is assumed to be constant—if it is not constant, then the voltage variations will affect the shape of the torque–speed curve.

Another effect *internal to the motor* that can also affect the shape of the torque–speed curve is armature reaction. If a motor has armature reaction, then as its load increases, the flux-weakening effects *reduce* its flux. As Equation (9-7) shows, the effect of a reduction in flux is to increase the motor’s speed at any given load over the speed it would run at without armature reaction. The torque–speed characteristic of a shunt motor with armature reaction is shown in Figure 9-6b. If a motor has compensating windings, of course there will be no flux-weakening problems in the machine, and the flux in the machine will be constant.

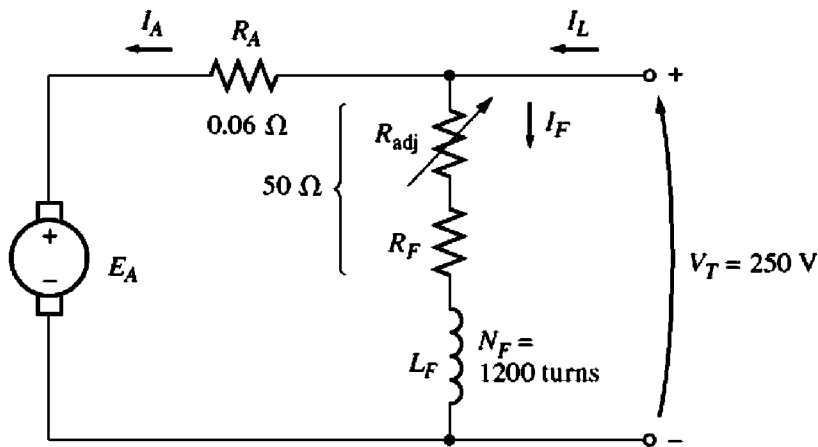

FIGURE 9-7
The shunt motor in Example 9-1.

If a shunt dc motor has compensating windings so that *its flux is constant regardless of load*, and the motor's speed and armature current are known at any one value of load, then it is possible to calculate its speed at any other value of load, as long as the armature current at that load is known or can be determined. Example 9-1 illustrates this calculation.

Example 9-1. A 50-hp, 250-V, 1200 r/min dc shunt motor with compensating windings has an armature resistance (including the brushes, compensating windings, and interpoles) of $0.06\ \Omega$. Its field circuit has a total resistance $R_{\text{adj}} + R_F$ of $50\ \Omega$, which produces a *no-load* speed of 1200 r/min. There are 1200 turns per pole on the shunt field winding (see Figure 9-7).

- Find the speed of this motor when its input current is 100 A.
- Find the speed of this motor when its input current is 200 A.
- Find the speed of this motor when its input current is 300 A.
- Plot the torque–speed characteristic of this motor.

Solution

The internal generated voltage of a dc machine with its speed expressed in revolutions per minute is given by

$$E_A = K' \phi n \quad (8-41)$$

Since the field current in the machine is constant (because V_T and the field resistance are both constant), and since there are no armature reaction effects, *the flux in this motor is constant*. The relationship between the speeds and internal generated voltages of the motor at two different load conditions is thus

$$\frac{E_{A2}}{E_{A1}} = \frac{K' \phi n_2}{K' \phi n_1} \quad (9-8)$$

The constant K' cancels, since it is a constant for any given machine, and the flux ϕ cancels as described above. Therefore,

$$n_2 = \frac{E_{A2}}{E_{A1}} n_1 \quad (9-9)$$

At no load, the armature current is zero, so $E_{A1} = V_T = 250$ V, while the speed $n_1 = 1200$ r/min. If we can calculate the internal generated voltage at any other load, it will be possible to determine the motor speed at that load from Equation (9-9).

(a) If $I_L = 100$ A, then the armature current in the motor is

$$\begin{aligned} I_A &= I_L - I_F = I_L - \frac{V_T}{R_F} \\ &= 100 \text{ A} - \frac{250 \text{ V}}{50 \Omega} = 95 \text{ A} \end{aligned}$$

Therefore, E_A at this load will be

$$\begin{aligned} E_A &= V_T - I_A R_A \\ &= 250 \text{ V} - (95 \text{ A})(0.06 \Omega) = 244.3 \text{ V} \end{aligned}$$

The resulting speed of the motor is

$$n_2 = \frac{E_{A2}}{E_{A1}} n_1 = \frac{244.3 \text{ V}}{250 \text{ V}} 1200 \text{ r/min} = 1173 \text{ r/min}$$

(b) If $I_L = 200$ A, then the armature current in the motor is

$$I_A = 200 \text{ A} - \frac{250 \text{ V}}{50 \Omega} = 195 \text{ A}$$

Therefore, E_A at this load will be

$$\begin{aligned} E_A &= V_T - I_A R_A \\ &= 250 \text{ V} - (195 \text{ A})(0.06 \Omega) = 238.3 \text{ V} \end{aligned}$$

The resulting speed of the motor is

$$n_2 = \frac{E_{A2}}{E_{A1}} n_1 = \frac{238.3 \text{ V}}{250 \text{ V}} 1200 \text{ r/min} = 1144 \text{ r/min}$$

(c) If $I_L = 300$ A, then the armature current in the motor is

$$\begin{aligned} I_A &= I_L - I_F = I_L - \frac{V_T}{R_F} \\ &= 300 \text{ A} - \frac{250 \text{ V}}{50 \Omega} = 295 \text{ A} \end{aligned}$$

Therefore, E_A at this load will be

$$\begin{aligned} E_A &= V_T - I_A R_A \\ &= 250 \text{ V} - (295 \text{ A})(0.06 \Omega) = 232.3 \text{ V} \end{aligned}$$

The resulting speed of the motor is

$$n_2 = \frac{E_{A2}}{E_{A1}} n_1 = \frac{232.3 \text{ V}}{250 \text{ V}} 1200 \text{ r/min} = 1115 \text{ r/min}$$

(d) To plot the output characteristic of this motor, it is necessary to find the torque corresponding to each value of speed. At no load, the induced torque τ_{ind} is clearly zero. The induced torque for any other load can be found from the fact that power converted in a dc motor is

$$\boxed{P_{\text{conv}} = E_A I_A = \tau_{\text{ind}} \omega} \quad (8-55, 8-56)$$

From this equation, the induced torque in a motor is

$$\tau_{\text{ind}} = \frac{E_A I_A}{\omega} \quad (9-10)$$

Therefore, the induced torque when $I_L = 100$ A is

$$\tau_{\text{ind}} = \frac{(244.3 \text{ V})(95 \text{ A})}{(1173 \text{ r/min})(1 \text{ min}/60\text{s})(2\pi \text{ rad/r})} = 190 \text{ N} \cdot \text{m}$$

The induced torque when $I_L = 200$ A is

$$\tau_{\text{ind}} = \frac{(238.3 \text{ V})(95 \text{ A})}{(1144 \text{ r/min})(1 \text{ min}/60\text{s})(2\pi \text{ rad/r})} = 388 \text{ N} \cdot \text{m}$$

The induced torque when $I_L = 300$ A is

$$\tau_{\text{ind}} = \frac{(232.3 \text{ V})(295 \text{ A})}{(1115 \text{ r/min})(1 \text{ min}/60\text{s})(2\pi \text{ rad/r})} = 587 \text{ N} \cdot \text{m}$$

The resulting torque–speed characteristic for this motor is plotted in Figure 9–8.

Nonlinear Analysis of a Shunt DC Motor

The flux ϕ and hence the internal generated voltage E_A of a dc machine is a *non-linear* function of its magnetomotive force. Therefore, anything that changes the

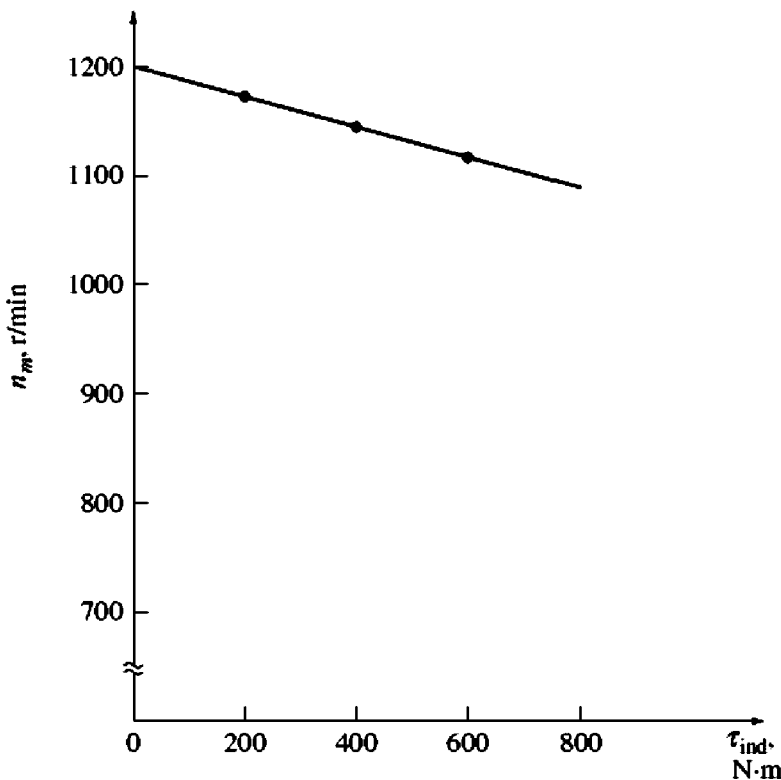

FIGURE 9–8
The torque–speed characteristic of the motor in Example 9–1.

magnetomotive force in a machine will have a nonlinear effect on the internal generated voltage of the machine. Since the change in E_A cannot be calculated analytically, the magnetization curve of the machine must be used to accurately determine its E_A for a given magnetomotive force. The two principal contributors to the magnetomotive force in the machine are its field current and its armature reaction, if present.

Since the magnetization curve is a direct plot of E_A versus I_F for a given speed ω_m , the effect of changing a machine's field current can be determined directly from its magnetization curve.

If a machine has armature reaction, its flux will be reduced with each increase in load. The total magnetomotive force in a shunt dc motor is the field circuit magnetomotive force less the magnetomotive force due to armature reaction (AR):

$$\mathcal{F}_{\text{net}} = N_F I_F - \mathcal{F}_{\text{AR}} \quad (9-11)$$

Since magnetization curves are expressed as plots of E_A versus field current, it is customary to define an *equivalent field current* that would produce the same output voltage as the combination of all the magnetomotive forces in the machine. The resulting voltage E_A can then be determined by locating that equivalent field current on the magnetization curve. The equivalent field current of a shunt dc motor is given by

$$I_F^* = I_F - \frac{\mathcal{F}_{\text{AR}}}{N_F} \quad (9-12)$$

One other effect must be considered when nonlinear analysis is used to determine the internal generated voltage of a dc motor. The magnetization curves for a machine are drawn for a particular speed, usually the rated speed of the machine. How can the effects of a given field current be determined if the motor is turning at other than rated speed?

The equation for the induced voltage in a dc machine when speed is expressed in revolutions per minute is

$$E_A = K' \phi n \quad (8-41)$$

For a given effective field current, the flux in a machine is fixed, so the internal generated voltage is related to speed by

$$\boxed{\frac{E_A}{E_{A0}} = \frac{n}{n_0}} \quad (9-13)$$

where E_{A0} and n_0 represent the reference values of voltage and speed, respectively. If the reference conditions are known from the magnetization curve and the actual E_A is known from Kirchhoff's voltage law, then it is possible to determine the actual speed n from Equation (9-13). The use of the magnetization curve and Equations (9-12) and (9-13) is illustrated in the following example, which analyzes a dc motor with armature reaction.

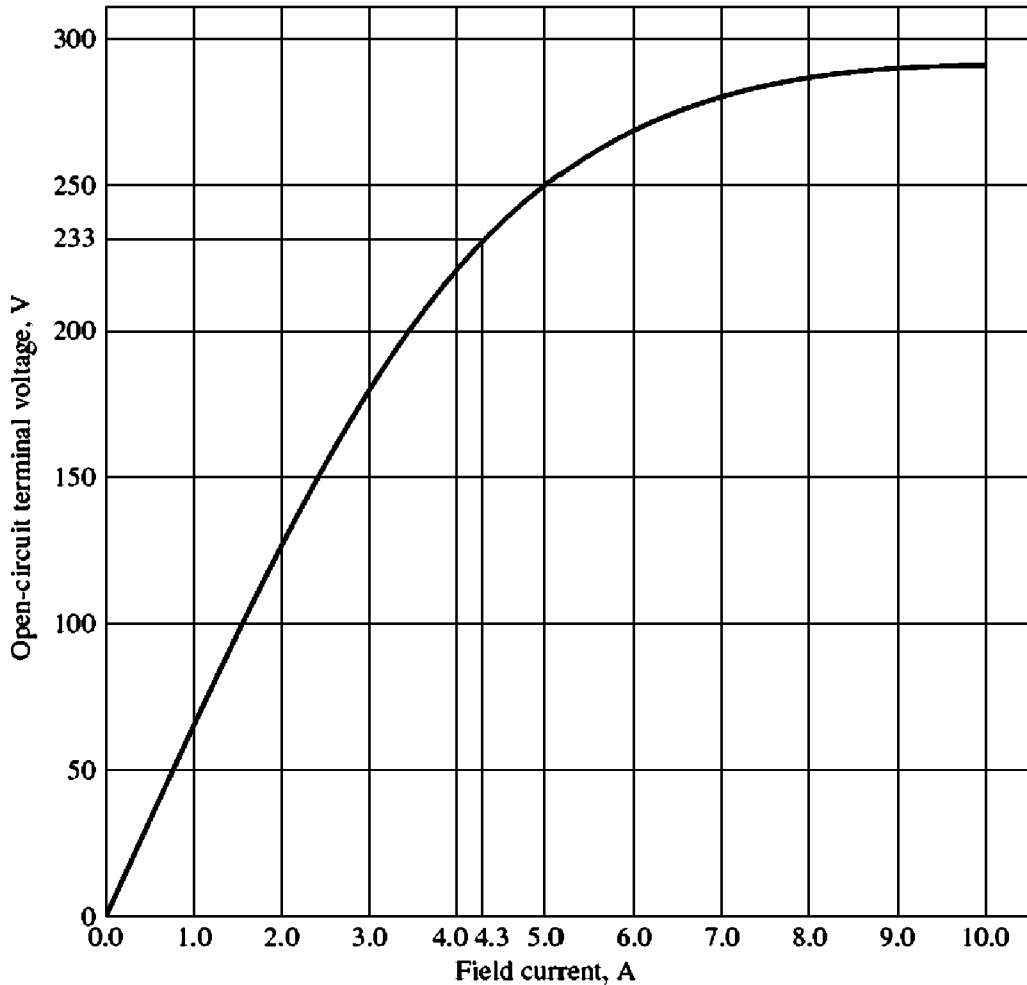

FIGURE 9-9

The magnetization curve of a typical 250-V dc motor, taken at a speed of 1200 r/min.

Example 9-2. A 50-hp, 250-V, 1200 r/min dc shunt motor *without* compensating windings has an armature resistance (including the brushes and interpoles) of 0.06Ω . Its field circuit has a total resistance $R_F + R_{adj}$ of 50Ω , which produces a no-load speed of 1200 r/min. There are 1200 turns per pole on the shunt field winding, and the armature reaction produces a demagnetizing magnetomotive force of $840 \text{ A} \cdot \text{turns}$ at a load current of 200 A. The magnetization curve of this machine is shown in Figure 9-9.

- Find the speed of this motor when its input current is 200 A.
- This motor is essentially identical to the one in Example 9-1 except for the absence of compensating windings. How does its speed compare to that of the previous motor at a load current of 200 A?
- Calculate and plot the torque–speed characteristic for this motor.

Solution

- If $I_L = 200 \text{ A}$, then the armature current of the motor is

$$\begin{aligned} I_A &= I_L - I_F = I_L - \frac{V_T}{R_F} \\ &= 200 \text{ A} - \frac{250 \text{ V}}{50 \Omega} = 195 \text{ A} \end{aligned}$$

Therefore, the internal generated voltage of the machine is

$$\begin{aligned} E_A &= V_T - I_A R_A \\ &= 250 \text{ V} - (195 \text{ A})(0.06 \Omega) = 238.3 \text{ V} \end{aligned}$$

At $I_L = 200 \text{ A}$, the demagnetizing magnetomotive force due to armature reaction is $840 \text{ A} \cdot \text{turns}$, so the effective shunt field current of the motor is

$$\begin{aligned} I_F^* &= I_F - \frac{\mathcal{F}_{AR}}{N_F} \\ &= 5.0 \text{ A} - \frac{840 \text{ A} \cdot \text{turns}}{1200 \text{ turns}} = 4.3 \text{ A} \end{aligned} \quad (9-12)$$

From the magnetization curve, this effective field current would produce an internal generated voltage E_{A0} of 233 V at a speed n_0 of 1200 r/min .

We know that the internal generated voltage E_{A0} would be 233 V at a speed of 1200 r/min . Since the actual internal generated voltage E_A is 238.3 V , the actual operating speed of the motor must be

$$\frac{E_A}{E_{A0}} = \frac{n}{n_0} \quad (9-13)$$

$$n = \frac{E_A}{E_{A0}} n_0 = \frac{238.3 \text{ V}}{233 \text{ V}} (1200 \text{ r/min}) = 1227 \text{ r/min}$$

- (b) At 200 A of load in Example 9-1, the motor's speed was $n = 1144 \text{ r/min}$. In this example, the motor's speed is 1227 r/min . Notice that the speed of the motor with armature reaction is higher than the speed of the motor with no armature reaction. This relative increase in speed is due to the flux weakening in the machine with armature reaction.
- (c) To derive the torque-speed characteristic of this motor, we must calculate the torque and speed for many different conditions of load. Unfortunately, the demagnetizing armature reaction magnetomotive force is only given for one condition of load (200 A). Since no additional information is available, we will assume that the strength of \mathcal{F}_{AR} varies linearly with load current.

A MATLAB M-file which automates this calculation and plots the resulting torque-speed characteristic is shown below. It performs the same steps as part a to determine the speed for each load current, and then calculates the induced torque at that speed. Note that it reads the magnetization curve from a file called `fig9_9.mat`. This file and the other magnetization curves in this chapter are available for download from the book's World Wide Web site (see Preface for details).

```
% M-file: shunt_ts_curve.m
% M-file create a plot of the torque-speed curve of the
% the shunt dc motor with armature reaction in
% Example 9-2.

% Get the magnetization curve. This file contains the
% three variables if_value, ea_value, and n_0.
load fig9_9.mat

% First, initialize the values needed in this program.
v_t = 250; % Terminal voltage (V)
```

```

r_f = 50;                % Field resistance (ohms)
r_a = 0.06;             % Armature resistance (ohms)
i_l = 10:10:300;       % Line currents (A)
n_f = 1200;            % Number of turns on field
f_ar0 = 840;           % Armature reaction @ 200 A (A-t/m)

% Calculate the armature current for each load.
i_a = i_l - v_t / r_f;

% Now calculate the internal generated voltage for
% each armature current.
e_a = v_t - i_a * r_a;

% Calculate the armature reaction MMF for each armature
% current.
f_ar = (i_a / 200) * f_ar0;

% Calculate the effective field current.
i_f = v_t / r_f - f_ar / n_f;

% Calculate the resulting internal generated voltage at
% 1200 r/min by interpolating the motor's magnetization
% curve.
e_a0 = interp1(if_values,ea_values,i_f,'spline');

% Calculate the resulting speed from Equation (9-13).
n = ( e_a ./ e_a0 ) * n_0;

% Calculate the induced torque corresponding to each
% speed from Equations (8-55) and (8-56).
t_ind = e_a .* i_a ./ (n * 2 * pi / 60);

% Plot the torque-speed curve
plot(t_ind,n,'Color','k','LineWidth',2.0);
hold on;
xlabel('\tau_{ind} (N-m)','Fontweight','Bold');
ylabel('\itn_{m} \rm\bf(r/min)','Fontweight','Bold');
('\bfShunt DC motor torque-speed characteristic')
axis([ 0 600 1100 1300]);
grid on;
hold off;

```

The resulting torque–speed characteristic is shown in Figure 9–10. Note that for any given load, the speed of the motor with armature reaction is higher than the speed of the motor without armature reaction.

Speed Control of Shunt DC Motors

How can the speed of a shunt dc motor be controlled? There are two common methods and one less common method in use. The common methods have already been seen in the simple linear machine in Chapter 1 and the simple rotating loop in Chapter 8. The two common ways in which the speed of a shunt dc machine can be controlled are by

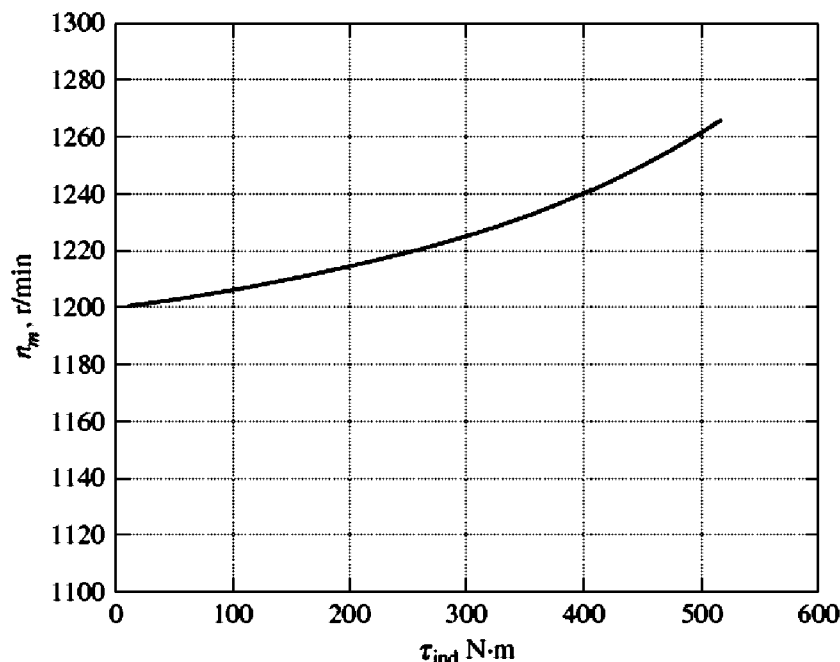

FIGURE 9-10

The torque–speed characteristic of the motor with armature reaction in Example 9-2.

1. Adjusting the field resistance R_F (and thus the field flux)
2. Adjusting the terminal voltage applied to the armature.

The less common method of speed control is by

3. Inserting a resistor in series with the armature circuit.

Each of these methods is described in detail below.

CHANGING THE FIELD RESISTANCE. To understand what happens when the field resistor of a dc motor is changed, assume that the field resistor increases and observe the response. If the field resistance increases, then the field current decreases ($I_F = V_T/R_F \uparrow$), and as the field current decreases, the flux ϕ decreases with it. A decrease in flux causes an instantaneous decrease in the internal generated voltage $E_A (= K\phi\omega)$, which causes a large increase in the machine's armature current, since

$$I_A \uparrow = \frac{V_T - E_A \downarrow}{R_A}$$

The induced torque in a motor is given by $\tau_{ind} = K\phi I_A$. Since the flux ϕ in this machine decreases while the current I_A increases, which way does the induced torque change? The easiest way to answer this question is to look at an example. Figure 9-11 shows a shunt dc motor with an internal resistance of 0.25Ω . It is currently operating with a terminal voltage of 250 V and an internal generated voltage of 245 V. Therefore, the armature current flow is $I_A = (250 \text{ V} -$

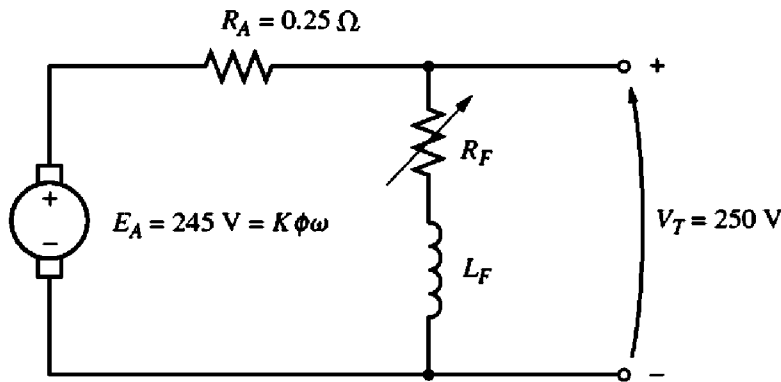

FIGURE 9-11

A 250-V shunt dc motor with typical values of E_A and R_A .

$245 \text{ V})/0.25 \Omega = 20 \text{ A}$. What happens in this motor *if there is a 1 percent decrease in flux*? If the flux decreases by 1 percent, then E_A must decrease by 1 percent too, because $E_A = K\phi\omega$. Therefore, E_A will drop to

$$E_{A2} = 0.99 E_{A1} = 0.99(245 \text{ V}) = 242.55 \text{ V}$$

The armature current must then rise to

$$I_A = \frac{250 \text{ V} - 242.55 \text{ V}}{0.25 \Omega} = 29.8 \text{ A}$$

Thus a 1 percent decrease in flux produced a 49 percent increase in armature current.

So to get back to the original discussion, the increase in current predominates over the decrease in flux, and the induced torque rises:

$$\tau_{\text{ind}} = K\phi \overset{\downarrow}{\uparrow} I_A$$

Since $\tau_{\text{ind}} > \tau_{\text{load}}$, the motor speeds up.

However, as the motor speeds up, the internal generated voltage E_A rises, causing I_A to fall. As I_A falls, the induced torque τ_{ind} falls too, and finally τ_{ind} again equals τ_{load} at a higher steady-state speed than originally.

To summarize the cause-and-effect behavior involved in this method of speed control:

1. Increasing R_F causes $I_F (= V_T/R_F \uparrow)$ to decrease.
2. Decreasing I_F decreases ϕ .
3. Decreasing ϕ lowers $E_A (= K\phi\downarrow\omega)$.
4. Decreasing E_A increases $I_A (= V_T - E_A \downarrow)/R_A$.
5. Increasing I_A increases $\tau_{\text{ind}} (= K\phi\downarrow I_A \uparrow)$, with the change in I_A dominant over the change in flux).
6. Increasing τ_{ind} makes $\tau_{\text{ind}} > \tau_{\text{load}}$, and the speed ω increases.
7. Increasing ω increases $E_A = K\phi\omega \uparrow$ again.

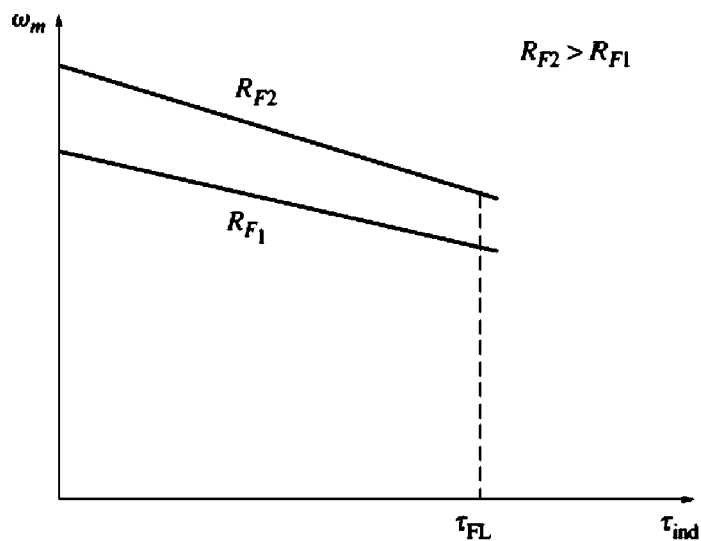

(a)

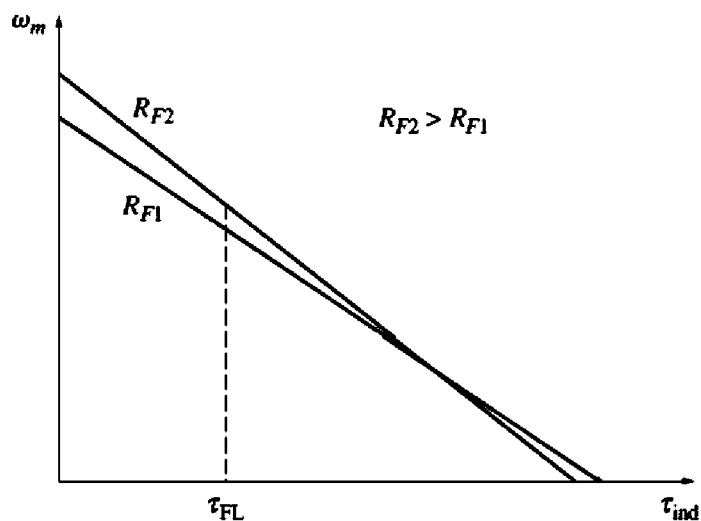

(b)

FIGURE 9-12
The effect of field resistance speed control on a shunt motor's torque-speed characteristic: (a) over the motor's normal operating range; (b) over the entire range from no-load to stall conditions.

- 8. Increasing E_A decreases I_A .
- 9. Decreasing I_A decreases τ_{ind} until $\tau_{ind} = \tau_{load}$ at a higher speed ω .

The effect of increasing the field resistance on the output characteristic of a shunt motor is shown in Figure 9-12a. Notice that as the flux in the machine decreases, the no-load speed of the motor increases, while the slope of the torque-speed curve becomes steeper. Naturally, decreasing R_F would reverse the whole process, and the speed of the motor would drop.

A WARNING ABOUT FIELD RESISTANCE SPEED CONTROL. The effect of increasing the field resistance on the output characteristic of a shunt dc motor is shown in Figure 9-12. Notice that as the flux in the machine decreases, the no-load speed of the motor increases, while the slope of the torque-speed curve becomes steeper. This shape is a consequence of Equation (9-7), which describes the terminal characteristic of the motor. In Equation (9-7), the no-load speed is

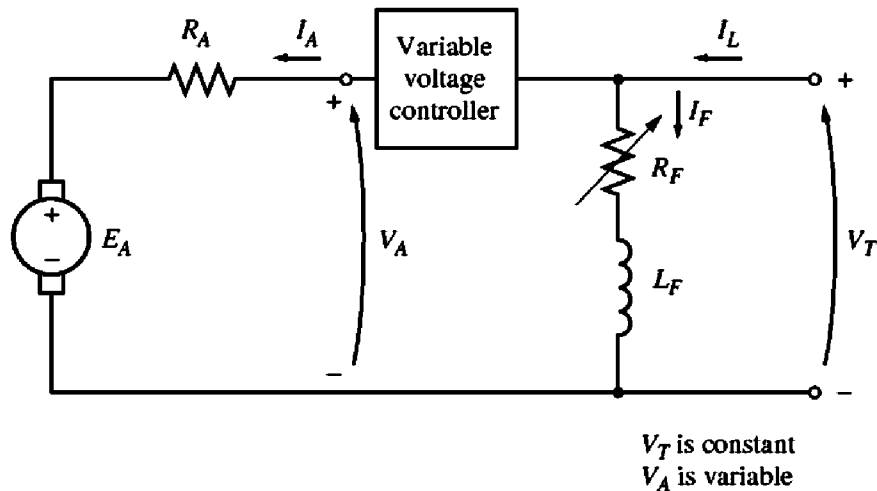

FIGURE 9-13

Armature voltage control of a shunt (or separately excited) dc motor.

proportional to the reciprocal of the flux in the motor, while the slope of the curve is proportional to the reciprocal of the flux squared. Therefore, a decrease in flux causes the slope of the torque–speed curve to become steeper.

Figure 9–12a shows the terminal characteristic of the motor over the range from no-load to full-load conditions. Over this range, an increase in field resistance increases the motor’s speed, as described above in this section. For motors operating between no-load and full-load conditions, an increase in R_F may reliably be expected to increase operating speed.

Now examine Figure 9–12b. This figure shows the terminal characteristic of the motor over the full range from no-load to stall conditions. It is apparent from the figure that at *very slow* speeds an increase in field resistance will actually *decrease* the speed of the motor. This effect occurs because, at very low speeds, the increase in armature current caused by the decrease in E_A is no longer large enough to compensate for the decrease in flux in the induced torque equation. With the flux decrease actually larger than the armature current increase, the induced torque decreases, and the motor slows down.

Some small dc motors used for control purposes actually operate at speeds close to stall conditions. For these motors, an increase in field resistance might have no effect, or it might even decrease the speed of the motor. Since the results are not predictable, field resistance speed control should not be used in these types of dc motors. Instead, the armature voltage method of speed control should be employed.

CHANGING THE ARMATURE VOLTAGE. The second form of speed control involves changing the voltage applied to the armature of the motor *without changing the voltage applied to the field*. A connection similar to that in Figure 9–13 is necessary for this type of control. In effect, the motor must be *separately excited* to use armature voltage control.

If the voltage V_A is increased, then the armature current in the motor must rise [$I_A = (V_A \uparrow - E_A)/R_A$]. As I_A increases, the induced torque $\tau_{\text{ind}} = K\phi I_A \uparrow$ increases, making $\tau_{\text{ind}} > \tau_{\text{load}}$, and the speed ω of the motor increases.

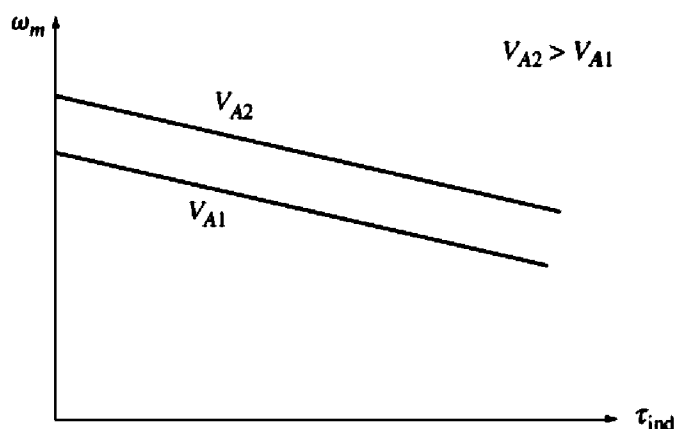

FIGURE 9-14

The effect of armature voltage speed control on a shunt motor's torque-speed characteristic.

But as the speed ω increases, the internal generated voltage $E_A (= K\phi\omega\uparrow)$ increases, causing the armature current to decrease. This decrease in I_A decreases the induced torque, causing τ_{ind} to equal τ_{load} at a higher rotational speed ω .

To summarize the cause-and-effect behavior in this method of speed control:

1. An increase in V_A increases $I_A [= (V_A \uparrow - E_A)/R_A]$.
2. Increasing I_A increases $\tau_{\text{ind}} (= K\phi I_A \uparrow)$.
3. Increasing τ_{ind} makes $\tau_{\text{ind}} > \tau_{\text{load}}$ increasing ω .
4. Increasing ω increases $E_A (= K\phi\omega \uparrow)$.
5. Increasing E_A decreases $I_A [= (V_A \uparrow - E_A)/R_A]$.
6. Decreasing I_A decreases τ_{ind} until $\tau_{\text{ind}} = \tau_{\text{load}}$ at a higher ω .

The effect of an increase in V_A on the torque-speed characteristic of a separately excited motor is shown in Figure 9-14. Notice that the no-load speed of the motor is shifted by this method of speed control, but the slope of the curve remains constant.

INSERTING A RESISTOR IN SERIES WITH THE ARMATURE CIRCUIT. If a resistor is inserted in series with the armature circuit, the effect is to drastically increase the slope of the motor's torque-speed characteristic, making it operate more slowly if loaded (Figure 9-15). This fact can easily be seen from Equation (9-7). The insertion of a resistor is a very wasteful method of speed control, since the losses in the inserted resistor are very large. For this reason, it is rarely used. It will be found only in applications in which the motor spends almost all its time operating at full speed or in applications too inexpensive to justify a better form of speed control.

The two most common methods of shunt motor speed control—field resistance variation and armature voltage variation—have different safe ranges of operation.

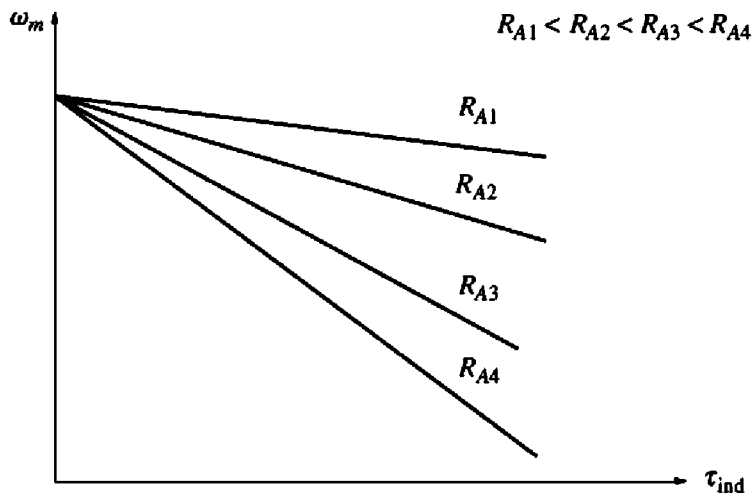

FIGURE 9-15

The effect of armature resistance speed control on a shunt motor's torque-speed characteristic.

In field resistance control, the lower the field current in a shunt (or separately excited) dc motor, the faster it turns; and the higher the field current, the slower it turns. Since an increase in field current causes a decrease in speed, there is always a minimum achievable speed by field circuit control. This minimum speed occurs when the motor's field circuit has the maximum permissible current flowing through it.

If a motor is operating at its rated terminal voltage, power, and field current, then it will be running at rated speed, also known as *base speed*. Field resistance control can control the speed of the motor for speeds above base speed but not for speeds below base speed. To achieve a speed slower than base speed by field circuit control would require excessive field current, possibly burning up the field windings.

In armature voltage control, the lower the armature voltage on a separately excited dc motor, the slower it turns; and the higher the armature voltage, the faster it turns. Since an increase in armature voltage causes an increase in speed, there is always a maximum achievable speed by armature voltage control. This maximum speed occurs when the motor's armature voltage reaches its maximum permissible level.

If the motor is operating at its rated voltage, field current, and power, it will be turning at base speed. Armature voltage control can control the speed of the motor for speeds below base speed but not for speeds above base speed. To achieve a speed faster than base speed by armature voltage control would require excessive armature voltage, possibly damaging the armature circuit.

These two techniques of speed control are obviously complementary. Armature voltage control works well for speeds below base speed, and field resistance or field current control works well for speeds above base speed. By combining the two speed-control techniques in the same motor, it is possible to get a range of speed variations of up to 40 to 1 or more. Shunt and separately excited dc motors have excellent speed control characteristics.

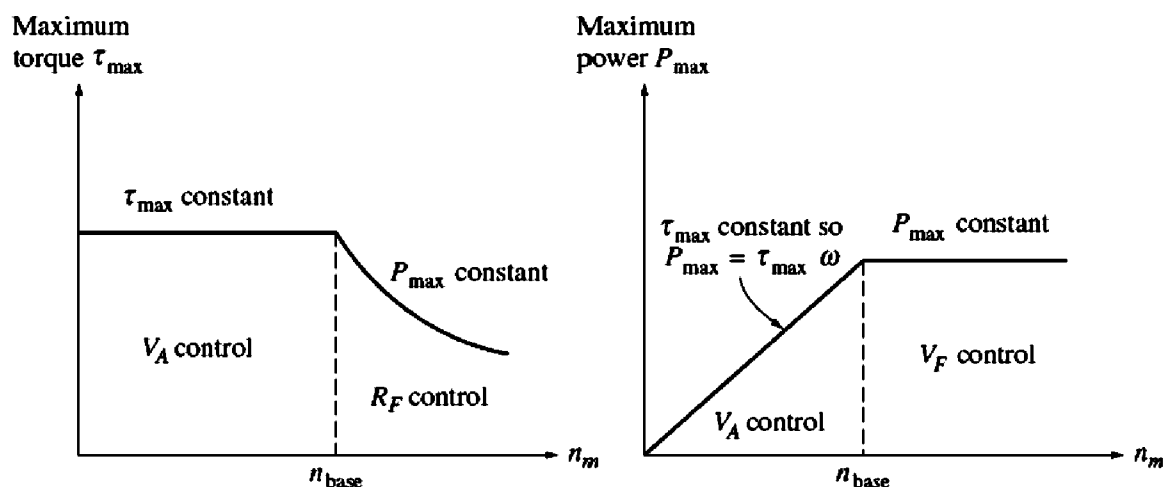

FIGURE 9-16

Power and torque limits as a function of speed for a shunt motor under armature volt and field resistance control.

There is a significant difference in the torque and power limits on the machine under these two types of speed control. The limiting factor in either case is the heating of the armature conductors, which places an upper limit on the magnitude of the armature current I_A .

For armature voltage control, *the flux in the motor is constant*, so the maximum torque in the motor is

$$\tau_{\max} = K\phi I_{A,\max} \quad (9-14)$$

This maximum torque is constant regardless of the speed of the rotation of the motor. Since the power out of the motor is given by $P = \tau\omega$, the maximum power of the motor at any speed under armature voltage control is

$$P_{\max} = \tau_{\max}\omega \quad (9-15)$$

Thus the maximum power out of the motor is directly proportional to its operating speed under armature voltage control.

On the other hand, when field resistance control is used, the flux does change. In this form of control, a speed increase is caused by a decrease in the machine's flux. In order for the armature current limit not to be exceeded, the induced torque limit must decrease as the speed of the motor increases. Since the power out of the motor is given by $P = \tau\omega$, and the torque limit decreases as the speed of the motor increases, *the maximum power out of a dc motor under field current control is constant, while the maximum torque varies as the reciprocal of the motor's speed.*

These shunt dc motor power and torque limitations for safe operation as a function of speed are shown in Figure 9-16.

The following examples illustrate how to find the new speed of a dc motor if it is varied by field resistance or armature voltage control methods.

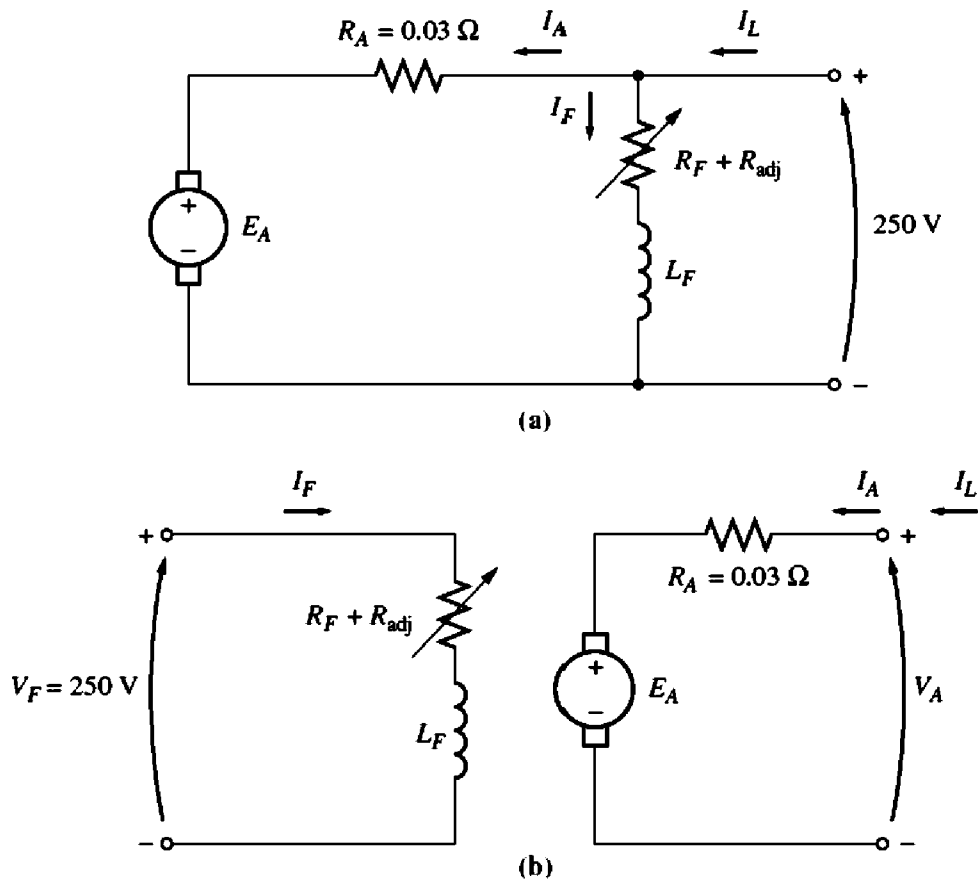

FIGURE 9-17

(a) The shunt motor in Example 9-3. (b) The separately excited dc motor in Example 9-4.

Example 9-3. Figure 9-17a shows a 100-hp, 250-V, 1200 r/min shunt dc motor with an armature resistance of 0.03Ω and a field resistance of 41.67Ω . The motor has compensating windings, so armature reaction can be ignored. Mechanical and core losses may be assumed to be negligible for the purposes of this problem. The motor is assumed to be driving a load with a line current of 126 A and an initial speed of 1103 r/min. To simplify the problem, assume that the amount of armature current drawn by the motor remains constant.

- If the machine's magnetization curve is shown in Figure 9-9, what is the motor's speed if the field resistance is raised to 50Ω ?
- Calculate and plot the speed of this motor as a function of the field resistance R_F assuming a constant-current load.

Solution

(a) The motor has an initial line current of 126 A, so the initial armature current is

$$I_{A1} = I_{L1} - I_{F1} = 126 \text{ A} - \frac{250 \text{ V}}{41.67 \Omega} = 120 \text{ A}$$

Therefore, the internal generated voltage is

$$\begin{aligned} E_{A1} &= V_T - I_{A1}R_A = 250 \text{ V} - (120 \text{ A})(0.03 \Omega) \\ &= 246.4 \text{ V} \end{aligned}$$

After the field resistance is increased to 50Ω , the field current will become

$$I_{F2} = \frac{V_T}{R_F} = \frac{250 \text{ V}}{50 \Omega} = 5 \text{ A}$$

The ratio of the internal generated voltage at one speed to the internal generated voltage at another speed is given by the ratio of Equation (8-41) at the two speeds:

$$\frac{E_{A2}}{E_{A1}} = \frac{K'\phi_2 n_2}{K'\phi_1 n_1} \quad (9-16)$$

Because the armature current is assumed constant, $E_{A1} = E_{A2}$, and this equation reduces to

$$1 = \frac{\phi_2 n_2}{\phi_1 n_1}$$

or
$$n_2 = \frac{\phi_1}{\phi_2} n_1 \quad (9-17)$$

A magnetization curve is a plot of E_A versus I_F for a given speed. Since the values of E_A on the curve are directly proportional to the flux, the ratio of the internal generated voltages read off the curve is equal to the ratio of the fluxes within the machine. At $I_F = 5 \text{ A}$, $E_{A0} = 250 \text{ V}$, while at $I_F = 6 \text{ A}$, $E_{A0} = 268 \text{ V}$. Therefore, the ratio of fluxes is given by

$$\frac{\phi_1}{\phi_2} = \frac{268 \text{ V}}{250 \text{ V}} = 1.076$$

and the new speed of the motor is

$$n_2 = \frac{\phi_1}{\phi_2} n_1 = (1.076)(1103 \text{ r/min}) = 1187 \text{ r/min}$$

(b) A MATLAB M-file that calculates the speed of the motor as a function of R_F is shown below.

```
% M-file: rf_speed_control.m
% M-file create a plot of the speed of a shunt dc
% motor as a function of field resistance, assuming
% a constant armature current (Example 9-3).

% Get the magnetization curve. This file contains the
% three variables if_value, ea_value, and n_0.
load fig9_9.mat

% First, initialize the values needed in this program.
v_t = 250;           % Terminal voltage (V)
r_f = 40:1:70;      % Field resistance (ohms)
r_a = 0.03;         % Armature resistance (ohms)
i_a = 120;          % Armature currents (A)

% The approach here is to calculate the e_a0 at the
% reference field current, and then to calculate the
% e_a0 for every field current. The reference speed is
% 1103 r/min, so by knowing the e_a0 and reference
% speed, we will be able to calculate the speed at the
% other field current.
```



```

% Calculate the internal generated voltage at 1200 r/min
% for the reference field current (5 A) by interpolating
% the motor's magnetization curve. The reference speed
% corresponding to this field current is 1103 r/min.
e_a0_ref = interp1(if_values,ea_values,5,'spline');
n_ref = 1103;

% Calculate the field current for each value of field
% resistance.
i_f = v_t ./ r_f;

% Calculate the E_a0 for each field current by
% interpolating the motor's magnetization curve.
e_a0 = interp1(if_values,ea_values,i_f,'spline');

% Calculate the resulting speed from Equation (9-17):
% n2 = (phi1 / phi2) * n1 = (e_a0_1 / e_a0_2 ) * n1
n2 = ( e_a0_ref ./ e_a0 ) * n_ref;

% Plot the speed versus r_f curve.
plot(r_f,n2,'Color','k','LineWidth',2.0);
hold on;
xlabel('Field resistance, \Omega','Fontweight','Bold');
ylabel('\itn_{m} \rm\bf(r/min)','Fontweight','Bold');
title ('Speed vs \itR_{F} \rm\bf for a Shunt DC Motor', ...
        'Fontweight','Bold');
axis([40 70 0 1400]);
grid on;
hold off;

```

The resulting plot is shown in Figure 9–18.

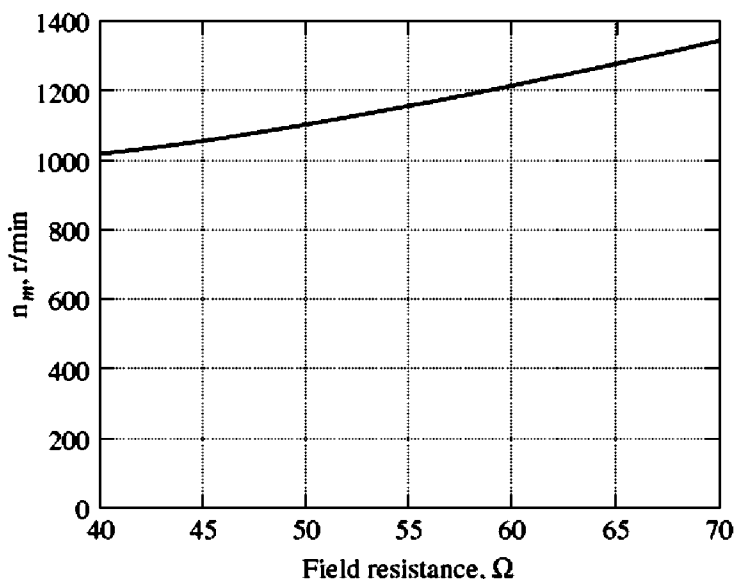

FIGURE 9–18

Plot of speed versus field resistance for the shunt dc motor of Example 9–3.

Note that the assumption of a constant armature current as R_F changes is not a very good one for real loads. The current in the armature will vary with speed in a fashion dependent on the torque required by the type of load attached to the motor. These differences will cause a motor's speed-versus- R_F curve to be slightly different than the one shown in Figure 9-18, but it will have a similar shape.

Example 9-4. The motor in Example 9-3 is now connected separately excited, as shown in Figure 9-17b. The motor is initially running with $V_A = 250$ V, $I_A = 120$ A, and $n = 1103$ r/min, while supplying a constant-torque load. What will the speed of this motor be if V_A is reduced to 200 V?

Solution

The motor has an initial line current of 120 A and an armature voltage V_A of 250 V, so the internal generated voltage E_A is

$$E_A = V_T - I_A R_A = 250 \text{ V} - (120 \text{ A})(0.03 \Omega) = 246.4 \text{ V}$$

By applying Equation (9-16) and realizing that the flux ϕ is constant, the motor's speed can be expressed as

$$\begin{aligned} \frac{E_{A2}}{E_{A1}} &= \frac{K' \phi_2 n_2}{K' \phi_1 n_1} & (9-16) \\ &= \frac{n_2}{n_1} \\ n_2 &= \frac{E_{A2}}{E_{A1}} n_1 \end{aligned}$$

To find E_{A2} use Kirchhoff's voltage law:

$$E_{A2} = V_T - I_{A2} R_A$$

Since the torque is constant and the flux is constant, I_A is constant. This yields a voltage of

$$E_{A2} = 200 \text{ V} - (120 \text{ A})(0.03 \Omega) = 196.4 \text{ V}$$

The final speed of the motor is thus

$$n_2 = \frac{E_{A2}}{E_{A1}} n_1 = \frac{196.4 \text{ V}}{246.4 \text{ V}} 1103 \text{ r/min} = 879 \text{ r/min}$$

The Effect of an Open Field Circuit

The previous section of this chapter contained a discussion of speed control by varying the field resistance of a shunt motor. As the field resistance increased, the speed of the motor increased with it. What would happen if this effect were taken to the extreme, if the field resistor *really* increased? What would happen if the field circuit actually opened while the motor was running? From the previous discussion, the flux in the machine would drop drastically, all the way down to ϕ_{res} , and $E_A (= K\phi\omega)$ would drop with it. This would cause a really enormous increase in the armature current, and the resulting induced torque would be quite a bit higher than the load torque on the motor. Therefore, the motor's speed starts to rise and just keeps going up.

The results of an open field circuit can be quite spectacular. When the author was an undergraduate, his laboratory group once made a mistake of this sort. The group was working with a small motor-generator set being driven by a 3-hp shunt dc motor. The motor was connected and ready to go, but there was just *one* little mistake—when the field circuit was connected, it was fused with a 0.3-A fuse instead of the 3-A fuse that was supposed to be used.

When the motor was started, it ran normally for about 3 s, and then suddenly there was a flash from the fuse. Immediately, the motor's speed skyrocketed. Someone turned the main circuit breaker off within a few seconds, but by that time the tachometer attached to the motor had pegged at 4000 r/min. The motor itself was only rated for 800 r/min.

Needless to say, that experience scared everyone present very badly and taught them to be *most* careful about field circuit protection. In dc motor starting and protection circuits, a *field loss relay* is normally included to disconnect the motor from the line in the event of a loss of field current.

A similar effect can occur in ordinary shunt dc motors operating with light fields if their armature reaction effects are severe enough. If the armature reaction on a dc motor is severe, an increase in load can weaken its flux enough to actually cause the motor's speed to rise. However, most loads have torque–speed curves whose torque *increases* with speed, so the increased speed of the motor increases its load, which increases its armature reaction, weakening its flux again. The weaker flux causes a further increase in speed, further increasing load, etc., until the motor overspeeds. This condition is known as *runaway*.

In motors operating with very severe load changes and duty cycles, this flux-weakening problem can be solved by installing compensating windings. Unfortunately, compensating windings are too expensive for use on ordinary run-of-the-mill motors. The solution to the runaway problem employed for less-expensive, less-severe duty motors is to provide a turn or two of cumulative compounding to the motor's poles. As the load increases, the magnetomotive force from the series turns increases, which counteracts the demagnetizing magnetomotive force of the armature reaction. A shunt motor equipped with just a few series turns like this is called a *stabilized shunt* motor.

9.5 THE PERMANENT-MAGNET DC MOTOR

A *permanent-magnet dc* (PMDC) *motor* is a dc motor whose poles are made of permanent magnets. Permanent-magnet dc motors offer a number of benefits compared with shunt dc motors in some applications. Since these motors do not require an external field circuit, they do not have the field circuit copper losses associated with shunt dc motors. Because no field windings are required, they can be smaller than corresponding shunt dc motors. PMDC motors are especially common in smaller fractional- and subfractional-horsepower sizes, where the expense and space of a separate field circuit cannot be justified.

However, PMDC motors also have disadvantages. Permanent magnets cannot produce as high a flux density as an externally supplied shunt field, so a

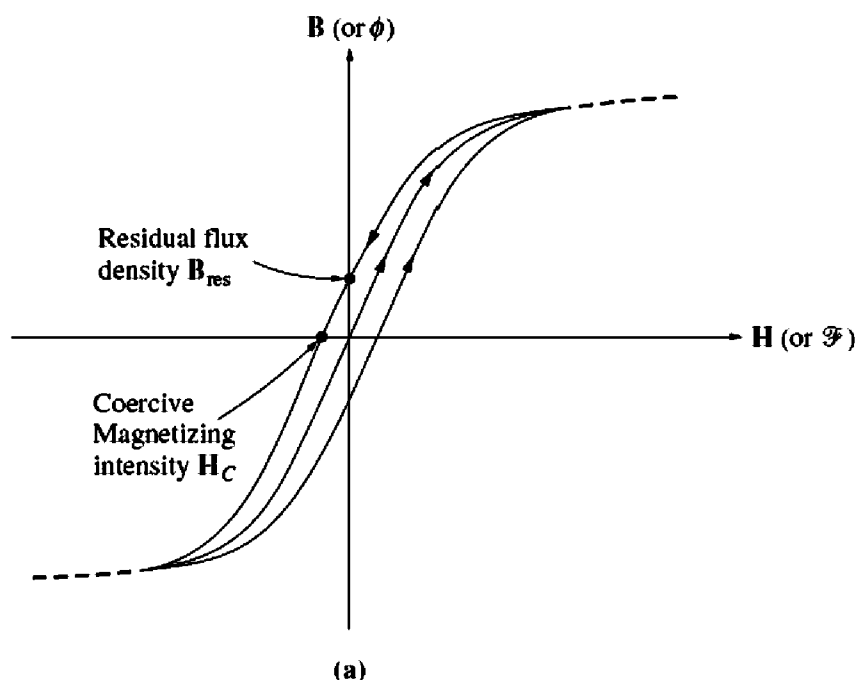

FIGURE 9-19

(a) The magnetization curve of a typical ferromagnetic material. Note the hysteresis loop. After a large magnetizing intensity H is applied to the core and then removed, a residual flux density B_{res} remains behind in the core. This flux can be brought to zero if a coercive magnetizing intensity H_C is applied to the core with the opposite polarity. In this case, a relatively small value of it will demagnetize the core.

PMDC motor will have a lower induced torque τ_{ind} per ampere of armature current I_A than a shunt motor of the same size and construction. In addition, PMDC motors run the risk of demagnetization. As mentioned in Chapter 8, the armature current I_A in a dc machine produces an armature magnetic field of its own. The armature mmf subtracts from the mmf of the poles under some portions of the pole faces and adds to the mmf of the poles under other portions of the pole faces (see Figures 8-23 and 8-25), reducing the overall net flux in the machine. This is the armature reaction effect. In a PMDC machine, the pole flux is just the residual flux in the permanent magnets. If the armature current becomes very large, there is some risk that the armature mmf may demagnetize the poles, permanently reducing and reorienting the residual flux in them. Demagnetization may also be caused by the excessive heating which can occur during prolonged periods of overload.

Figure 9-19a shows a magnetization curve for a typical ferromagnetic material. It is a plot of flux density B versus magnetizing intensity H (or equivalently, a plot of flux ϕ versus mmf \mathcal{F}). When a strong external magnetomotive force is applied to this material and then removed, a residual flux B_{res} will remain in the material. To force the residual flux to zero, it is necessary to apply a coercive magnetizing intensity H_C with a polarity opposite to the polarity of the magnetizing intensity H that originally established the magnetic field. For normal machine

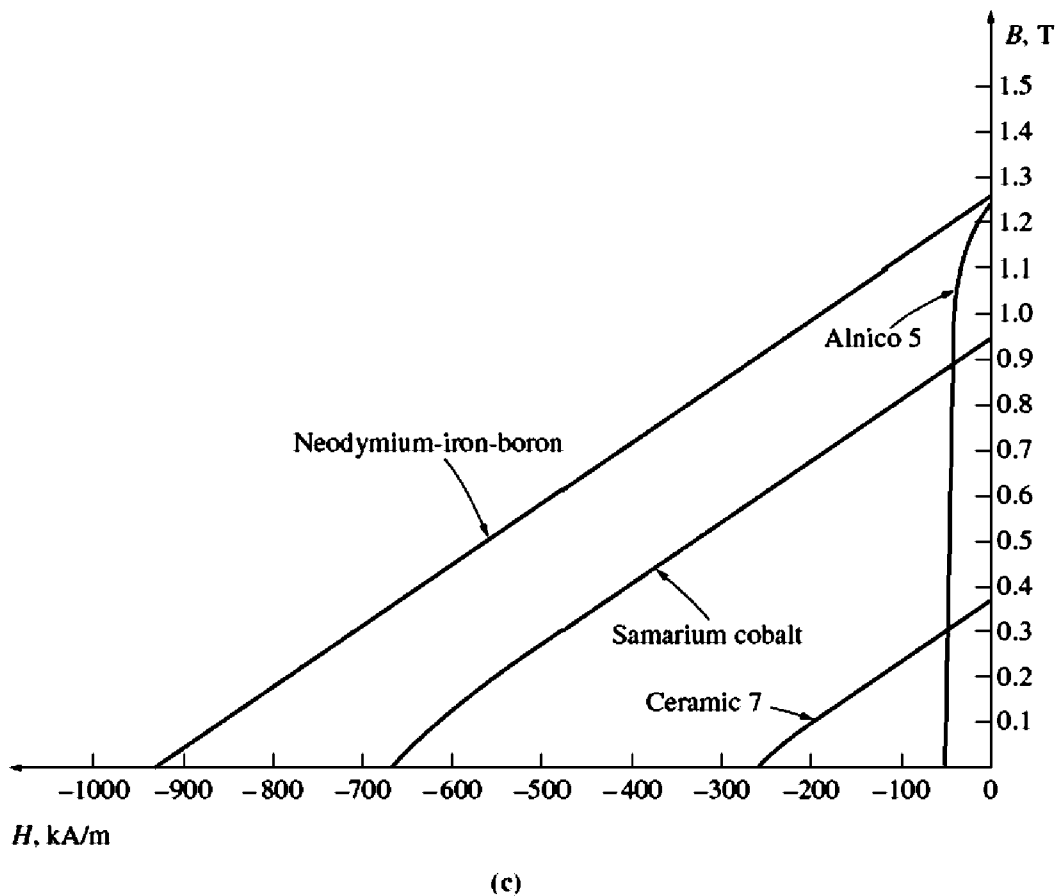
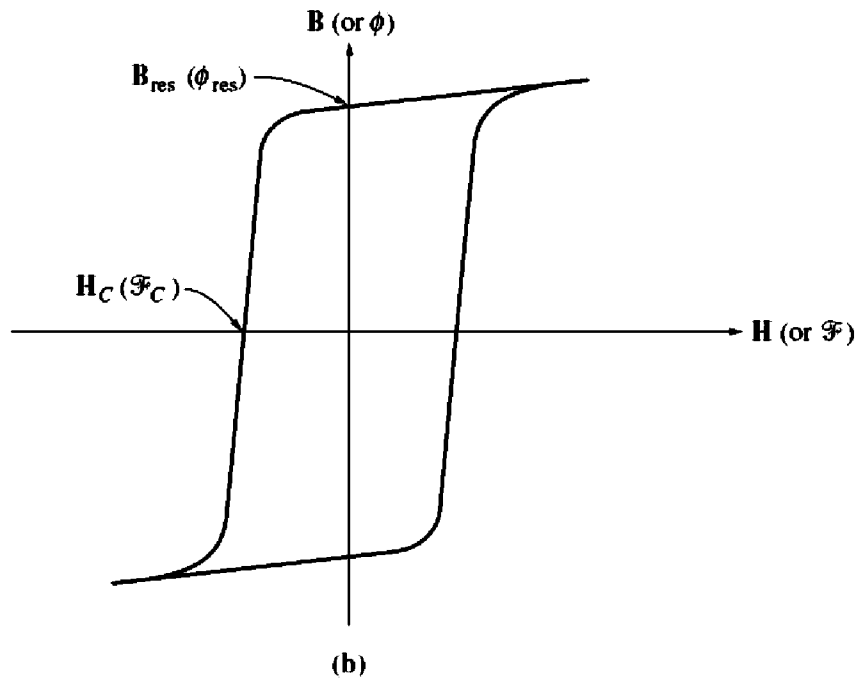

FIGURE 9-19 (concluded)

(b) The magnetization curve of a ferromagnetic material suitable for use in permanent magnets. Note the high residual flux density B_{res} and the relatively large coercive magnetizing intensity H_C . (c) The second quadrant of the magnetization curves of some typical magnetic materials. Note that the rare-earth magnets combine both a high residual flux and a high coercive magnetizing intensity.

applications such as rotors and stators, a ferromagnetic material should be picked which has as small a B_{res} and H_C as possible, since such a material will have low hysteresis losses.

On the other hand, a good material for the poles of a PMDC motor should have *as large a residual flux density B_{res} as possible*, while simultaneously having *as large a coercive magnetizing intensity H_C as possible*. The magnetization curve of such a material is shown in Figure 9–19b. The large B_{res} produces a large flux in the machine, while the large H_C means that a very large current would be required to demagnetize the poles.

In the last 40 years, a number of new magnetic materials have been developed which have desirable characteristics for making permanent magnets. The major types of materials are the ceramic (ferrite) magnetic materials and the rare-earth magnetic materials. Figure 9–19c shows the second quadrant of the magnetization curves of some typical ceramic and rare-earth magnets, compared to the magnetization curve of a conventional ferromagnetic alloy (Alnico 5). It is obvious from the comparison that the best rare-earth magnets can produce the same residual flux as the best conventional ferromagnetic alloys, while simultaneously being largely immune to demagnetization problems due to armature reaction.

A permanent-magnet dc motor is basically the same machine as a shunt dc motor, except that *the flux of a PMDC motor is fixed*. Therefore, it is not possible to control the speed of a PMDC motor by varying the field current or flux. The only methods of speed control available for a PMDC motor are armature voltage control and armature resistance control.

For more information about PMDC motors, see References 4 and 10.

9.6 THE SERIES DC MOTOR

A series dc motor is a dc motor whose field windings consist of a relatively few turns connected in series with the armature circuit. The equivalent circuit of a series dc motor is shown in Figure 9–20. In a series motor, the armature current, field current, and line current are all the same. The Kirchhoff's voltage law equation for this motor is

$$V_T = E_A + I_A(R_A + R_S) \quad (9-18)$$

Induced Torque in a Series DC Motor

The terminal characteristic of a series dc motor is very different from that of the shunt motor previously studied. The basic behavior of a series dc motor is due to the fact that *the flux is directly proportional to the armature current*, at least until saturation is reached. As the load on the motor increases, its flux increases too. As seen earlier, an increase in flux in the motor causes a decrease in its speed. The result is that a series motor has a sharply drooping torque–speed characteristic.

The induced torque in this machine is given by Equation (8–49):

$$\tau_{ind} = K\phi I_A \quad (8-49)$$

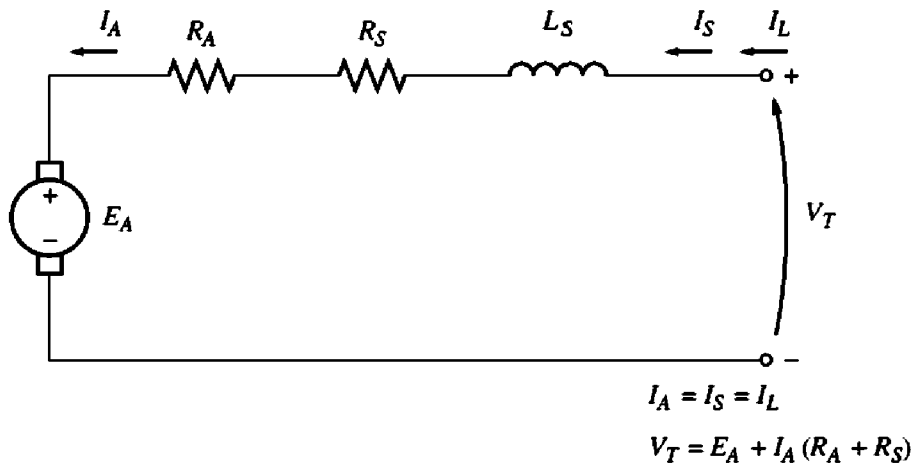
**FIGURE 9-20**

The equivalent circuit of a series dc motor.

The flux in this machine is directly proportional to its armature current (at least until the metal saturates). Therefore, the flux in the machine can be given by

$$\phi = cI_A \quad (9-19)$$

where c is a constant of proportionality. The induced torque in this machine is thus given by

$$\tau_{\text{ind}} = K\phi I_A = KcI_A^2 \quad (9-20)$$

In other words, the torque in the motor is proportional to the square of its armature current. As a result of this relationship, it is easy to see that a series motor gives more torque per ampere than any other dc motor. It is therefore used in applications requiring very high torques. Examples of such applications are the starter motors in cars, elevator motors, and tractor motors in locomotives.

The Terminal Characteristic of a Series DC Motor

To determine the terminal characteristic of a series dc motor, an analysis will be based on the assumption of a linear magnetization curve, and then the effects of saturation will be considered in a graphical analysis.

The assumption of a linear magnetization curve implies that the flux in the motor will be given by Equation (9-19):

$$\phi = cI_A \quad (9-19)$$

This equation will be used to derive the torque–speed characteristic curve for the series motor.

The derivation of a series motor's torque–speed characteristic starts with Kirchhoff's voltage law:

$$V_T = E_A + I_A(R_A + R_S) \quad (9-18)$$

From Equation (9-20), the armature current can be expressed as

$$I_A = \sqrt{\frac{\tau_{\text{ind}}}{Kc}}$$

Also, $E_A = K\phi\omega$. Substituting these expressions in Equation (9–18) yields

$$V_T = K\phi\omega + \sqrt{\frac{\tau_{\text{ind}}}{Kc}}(R_A + R_S) \quad (9-21)$$

If the flux can be eliminated from this expression, it will directly relate the torque of a motor to its speed. To eliminate the flux from the expression, notice that

$$I_A = \frac{\phi}{c}$$

and the induced torque equation can be rewritten as

$$\tau_{\text{ind}} = \frac{K}{c} \phi^2$$

Therefore, the flux in the motor can be rewritten as

$$\phi = \sqrt{\frac{c}{K}} \sqrt{\tau_{\text{ind}}} \quad (9-22)$$

Substituting Equation (9–22) into Equation (9–21) and solving for speed yields

$$\begin{aligned} V_T &= K \sqrt{\frac{c}{K}} \sqrt{\tau_{\text{ind}}} \omega + \sqrt{\frac{\tau_{\text{ind}}}{Kc}} (R_A + R_S) \\ \sqrt{Kc} \sqrt{\tau_{\text{ind}}} \omega &= V_T - \frac{R_A + R_S}{\sqrt{Kc}} \sqrt{\tau_{\text{ind}}} \\ \omega &= \frac{V_T}{\sqrt{Kc} \sqrt{\tau_{\text{ind}}}} - \frac{R_A + R_S}{Kc} \end{aligned}$$

The resulting torque–speed relationship is

$$\boxed{\omega = \frac{V_T}{\sqrt{Kc}} \frac{1}{\sqrt{\tau_{\text{ind}}}} - \frac{R_A + R_S}{Kc}} \quad (9-23)$$

Notice that for an unsaturated series motor the speed of the motor varies as the reciprocal of the square root of the torque. That is quite an unusual relationship! This ideal torque–speed characteristic is plotted in Figure 9–21.

One disadvantage of series motors can be seen immediately from this equation. When the torque on this motor goes to zero, its speed goes to infinity. In practice, the torque can never go entirely to zero because of the mechanical, core, and stray losses that must be overcome. However, if no other load is connected to the motor, it can turn fast enough to seriously damage itself. *Never* completely unload a series motor, and never connect one to a load by a belt or other mechanism that could break. If that were to happen and the motor were to become unloaded while running, the results could be serious.

The nonlinear analysis of a series dc motor with magnetic saturation effects, but ignoring armature reaction, is illustrated in Example 9–5.

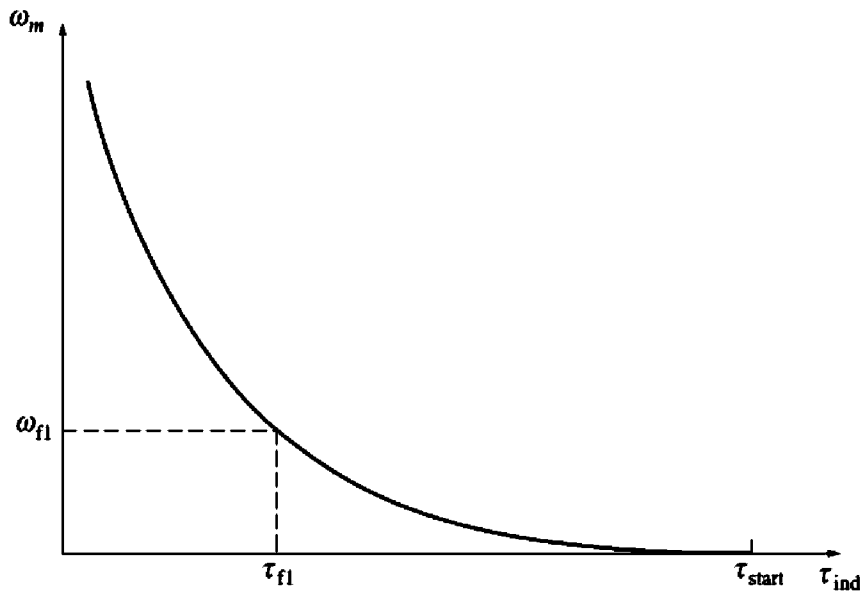

FIGURE 9-21
The torque–speed characteristic of a series dc motor.

Example 9-5. Figure 9-20 shows a 250-V series dc motor with compensating windings, and a total series resistance $R_A + R_S$ of 0.08Ω . The series field consists of 25 turns per pole, with the magnetization curve shown in Figure 9-22.

- Find the speed and induced torque of this motor for when its armature current is 50 A.
- Calculate and plot the torque–speed characteristic for this motor.

Solution

- To analyze the behavior of a series motor with saturation, pick points along the operating curve and find the torque and speed for each point. Notice that the magnetization curve is given in units of magnetomotive force (ampere-turns) versus E_A for a speed of 1200 r/min, so calculated E_A values must be compared to the equivalent values at 1200 r/min to determine the actual motor speed.

For $I_A = 50 \text{ A}$,

$$E_A = V_T - I_A(R_A + R_S) = 250 \text{ V} - (50 \text{ A})(0.08 \Omega) = 246 \text{ V}$$

Since $I_A = I_F = 50 \text{ A}$, the magnetomotive force is

$$\mathcal{F} = NI = (25 \text{ turns})(50 \text{ A}) = 1250 \text{ A} \cdot \text{turns}$$

From the magnetization curve at $\mathcal{F} = 1250 \text{ A} \cdot \text{turns}$, $E_{A0} = 80 \text{ V}$. To get the correct speed of the motor, remember that, from Equation (9-13),

$$\begin{aligned} n &= \frac{E_A}{E_{A0}} n_0 \\ &= \frac{246 \text{ V}}{80 \text{ V}} 120 \text{ r/min} = 3690 \text{ r/min} \end{aligned}$$

To find the induced torque supplied by the motor at that speed, recall that $P_{\text{conv}} = E_A I_A = \tau_{\text{ind}} \omega$. Therefore,

$$\tau_{\text{ind}} = \frac{E_A I_A}{\omega}$$

$$= \frac{(246 \text{ V})(50 \text{ A})}{(3690 \text{ r/min})(1 \text{ min}/60 \text{ s})(2\pi \text{ rad/r})} = 31.8 \text{ N} \cdot \text{m}$$

(b) To calculate the complete torque–speed characteristic, we must repeat the steps in *a* for many values of armature current. A MATLAB M-file that calculates the torque–speed characteristics of the series dc motor is shown below. Note that the magnetization curve used by this program works in terms of field magnetomotive force instead of effective field current.

```
% M-file: series_ts_curve.m
% M-file create a plot of the torque-speed curve of the
% the series dc motor with armature reaction in
% Example 9-5.

% Get the magnetization curve. This file contains the
% three variables mmf_values, ea_values, and n_0.
load fig9_22.mat
```

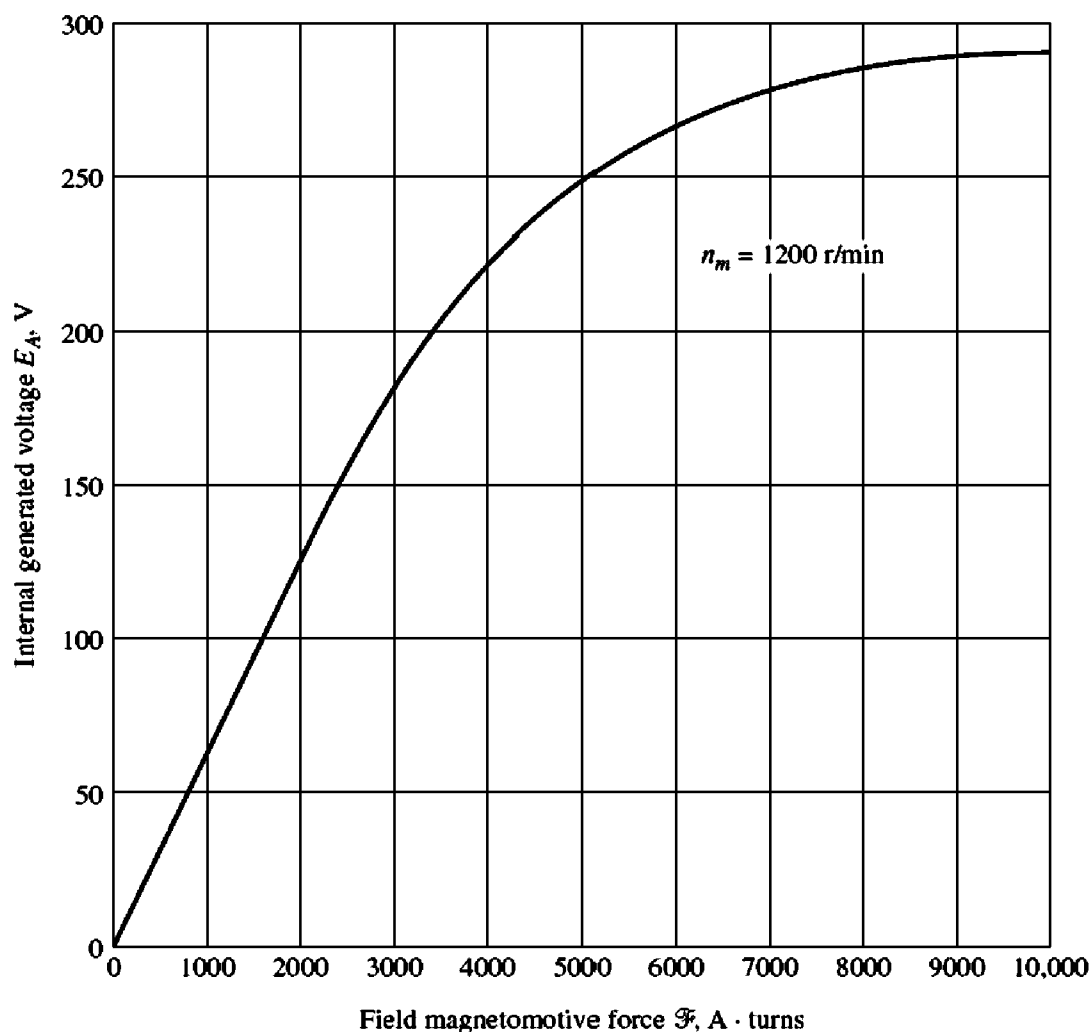

FIGURE 9-22

The magnetization curve of the motor in Example 9-5. This curve was taken at speed $n_m = 1200 \text{ r/min}$.

```

% First, initialize the values needed in this program.
v_t = 250;           % Terminal voltage (V)
r_a = 0.08;         % Armature + field resistance (ohms)
i_a = 10:10:300;    % Armature (line) currents (A)
n_s = 25;           % Number of series turns on field

% Calculate the MMF for each load
f = n_s * i_a;

% Calculate the internal generated voltage e_a.
e_a = v_t - i_a * r_a;

% Calculate the resulting internal generated voltage at
% 1200 r/min by interpolating the motor's magnetization
% curve.
e_a0 = interp1(mmf_values,ea_values,f,'spline');

% Calculate the motor's speed from Equation (9-13).
n = (e_a ./ e_a0) * n_0;

% Calculate the induced torque corresponding to each
% speed from Equations (8-55) and (8-56).
t_ind = e_a .* i_a ./ (n * 2 * pi / 60);

% Plot the torque-speed curve
plot(t_ind,n,'Color','k','LineWidth',2.0);
hold on;
xlabel('\tau_{ind} (N-m)','Fontweight','Bold');
ylabel('\itn_{m} \rm\bf(r/min)','Fontweight','Bold');
title('Series DC Motor Torque-Speed Characteristic', ...
      'Fontweight','Bold');
axis([ 0 700 0 5000]);
grid on;
hold off;

```

The resulting motor torque–speed characteristic is shown in Figure 9–23. Notice the severe overspeeding at very small torques.

Speed Control of Series DC Motors

Unlike with the shunt dc motor, there is only one efficient way to change the speed of a series dc motor. That method is to change the terminal voltage of the motor. If the terminal voltage is increased, the first term in Equation (9–23) is increased, resulting in a *higher speed for any given torque*.

The speed of series dc motors can also be controlled by the insertion of a series resistor into the motor circuit, but this technique is very wasteful of power and is used only for intermittent periods during the start-up of some motors.

Until the last 40 years or so, there was no convenient way to change V_T , so the only method of speed control available was the wasteful series resistance method. That has all changed today with the introduction of solid-state control circuits. Techniques of obtaining variable terminal voltages were discussed in Chapter 3 and will be considered further later in this chapter.

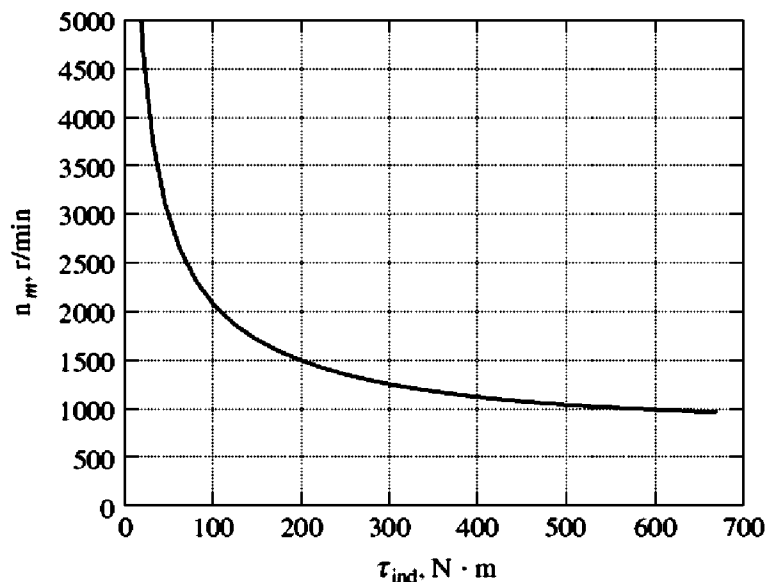

FIGURE 9-23

The torque–speed characteristic of the series dc motor in Example 9-5.

9.7 THE COMPOUNDED DC MOTOR

A compounded dc motor is a motor with *both a shunt and a series field*. Such a motor is shown in Figure 9-24. The dots that appear on the two field coils have the same meaning as the dots on a transformer: *Current flowing into a dot produces a positive magnetomotive force*. If current flows into the dots on both field coils, the resulting magnetomotive forces add to produce a larger total magnetomotive force. This situation is known as *cumulative compounding*. If current flows into the dot on one field coil and out of the dot on the other field coil, the resulting magnetomotive forces subtract. In Figure 9-24 the round dots correspond to cumulative compounding of the motor, and the squares correspond to differential compounding.

The Kirchhoff's voltage law equation for a compounded dc motor is

$$V_T = E_A + I_A(R_A + R_S) \quad (9-24)$$

The currents in the compounded motor are related by

$$I_A = I_L - I_F \quad (9-25)$$

$$I_F = \frac{V_T}{R_F} \quad (9-26)$$

The net magnetomotive force and the effective shunt field current in the compounded motor are given by

$$\mathcal{F}_{\text{net}} = \mathcal{F}_F \pm \mathcal{F}_{SE} - \mathcal{F}_{AR} \quad (9-27)$$

and

$$I_F^* = I_F \pm \frac{N_{SE}}{N_F} I_A - \frac{\mathcal{F}_{AR}}{N_F} \quad (9-28)$$

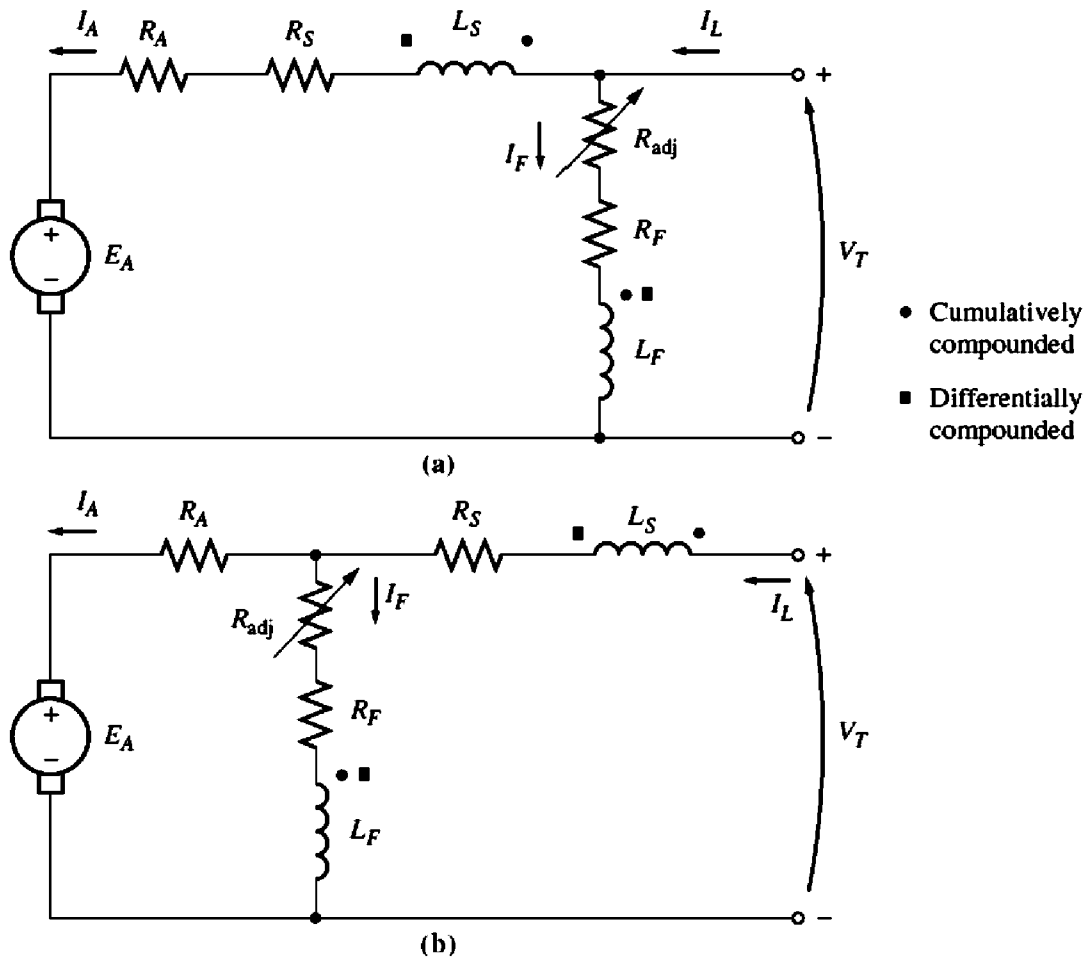

FIGURE 9-24

The equivalent circuit of compounded dc motors: (a) long-shunt connection; (b) short-shunt connection.

where the positive sign in the equations is associated with a cumulatively compounded motor and the negative sign is associated with a differentially compounded motor.

The Torque–Speed Characteristic of a Cumulatively Compounded DC Motor

In the cumulatively compounded dc motor, there is a component of flux which is constant and another component which is proportional to its armature current (and thus to its load). Therefore, the cumulatively compounded motor has a higher starting torque than a shunt motor (whose flux is constant) but a lower starting torque than a series motor (whose entire flux is proportional to armature current).

In a sense, the cumulatively compounded dc motor combines the best features of both the shunt and the series motors. Like a series motor, it has extra torque for starting; like a shunt motor, it does not overspeed at no load.

At light loads, the series field has a very small effect, so the motor behaves approximately as a shunt dc motor. As the load gets very large, the series flux

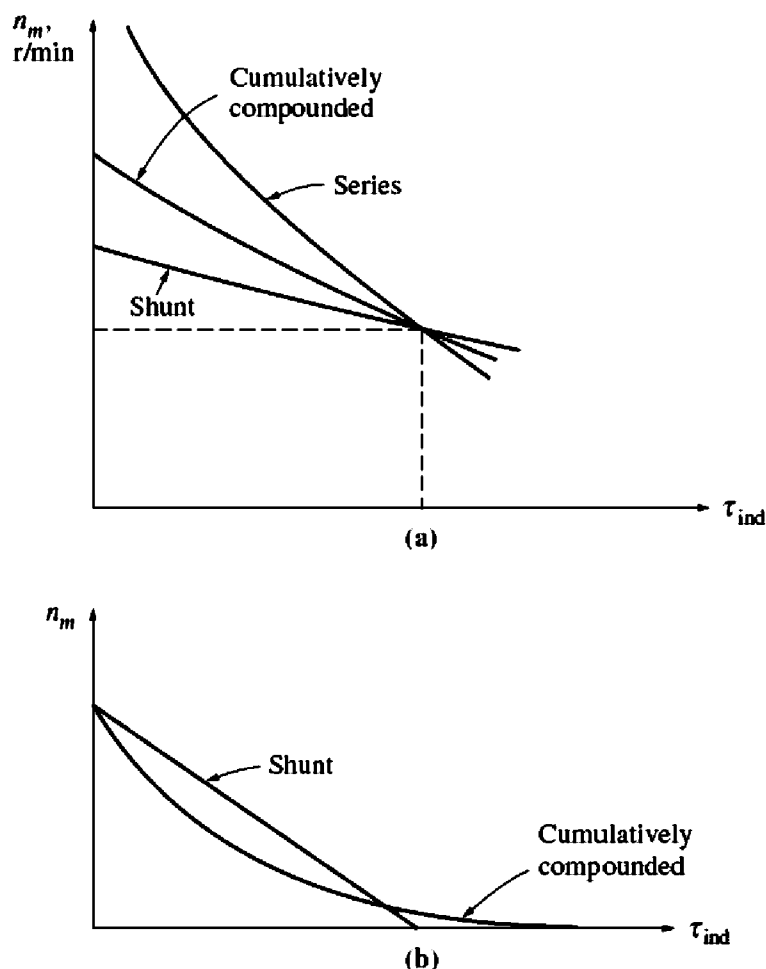

FIGURE 9-25

(a) The torque–speed characteristic of a cumulatively compounded dc motor compared to series and shunt motors with the same full-load rating. (b) The torque–speed characteristic of a cumulatively compounded dc motor compared to a shunt motor with the same no-load speed.

becomes quite important and the torque–speed curve begins to look like a series motor’s characteristic. A comparison of the torque–speed characteristics of each of these types of machines is shown in Figure 9–25.

To determine the characteristic curve of a cumulatively compounded dc motor by nonlinear analysis, the approach is similar to that for the shunt and series motors seen before. Such an analysis will be illustrated in a later example.

The Torque–Speed Characteristic of a Differentially Compounded DC Motor

In a differentially compounded dc motor, *the shunt magnetomotive force and series magnetomotive force subtract from each other*. This means that as the load on the motor increases, I_A increases and *the flux in the motor decreases*. But as the flux decreases, the speed of the motor increases. This speed increase causes another increase in load, which further increases I_A , further decreasing the flux, and increasing the speed again. The result is that a differentially compounded motor is

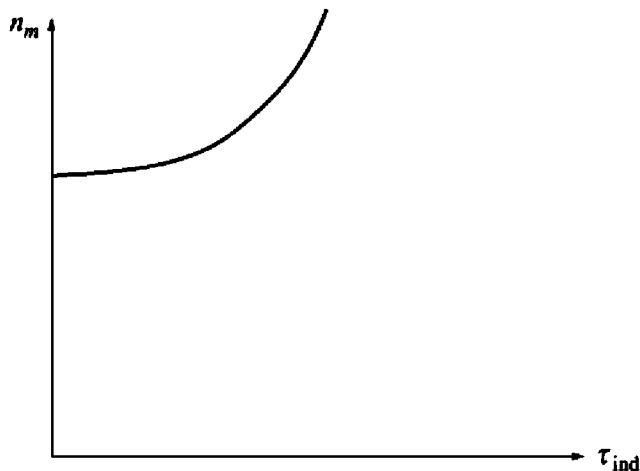

FIGURE 9-26
The torque–speed characteristic of a differentially compounded dc motor.

unstable and tends to run away. This instability is *much* worse than that of a shunt motor with armature reaction. It is so bad that a differentially compounded motor is unsuitable for any application.

To make matters worse, it is impossible to start such a motor. At starting conditions the armature current and the series field current are very high. Since the series flux subtracts from the shunt flux, the series field can actually reverse the magnetic polarity of the machine's poles. The motor will typically remain still or turn slowly in the wrong direction while burning up, because of the excessive armature current. When this type of motor is to be started, its series field must be short-circuited, so that it behaves as an ordinary shunt motor during the starting period.

Because of the stability problems of the differentially compounded dc motor, it is almost never *intentionally* used. However, a differentially compounded motor can result if the direction of power flow reverses in a cumulatively compounded generator. For that reason, if cumulatively compounded dc generators are used to supply power to a system, they will have a reverse-power trip circuit to disconnect them from the line if the power flow reverses. No motor–generator set in which power is expected to flow in both directions can use a differentially compounded motor, and therefore it cannot use a cumulatively compounded generator.

A typical terminal characteristic for a differentially compounded dc motor is shown in Figure 9-26.

The Nonlinear Analysis of Compounded DC Motors

The determination of the torque and speed of a compounded dc motor is illustrated in Example 9-6.

Example 9-6. A 100-hp, 250-V compounded dc motor with compensating windings has an internal resistance, including the series winding, of $0.04\ \Omega$. There are 1000 turns per pole on the shunt field and 3 turns per pole on the series winding. The machine is shown in Figure 9-27, and its magnetization curve is shown in Figure 9-9. At no load, the field resistor has been adjusted to make the motor run at 1200 r/min. The core, mechanical, and stray losses may be neglected.

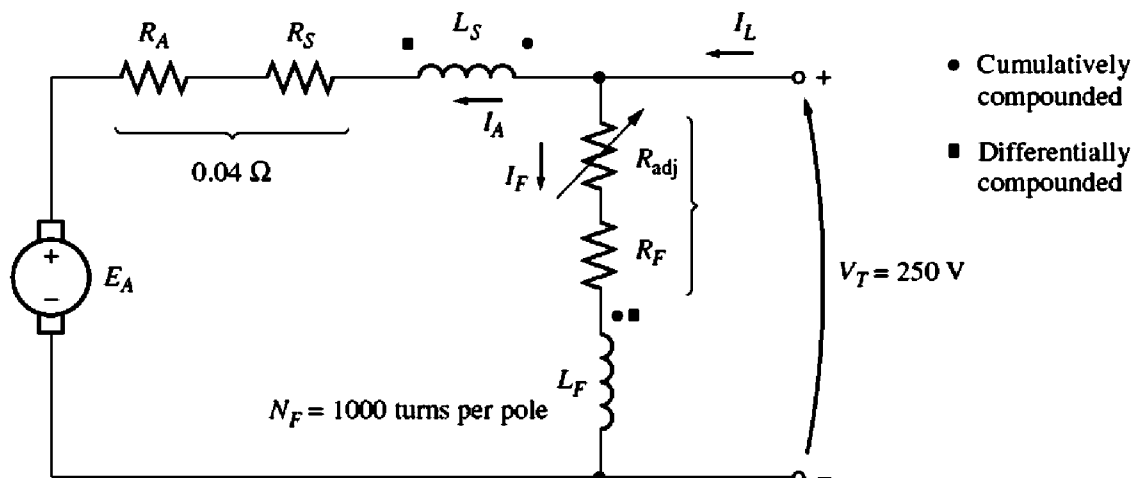

FIGURE 9-27
The compounded dc motor in Example 9-6.

- (a) What is the shunt field current in this machine at no load?
 (b) If the motor is cumulatively compounded, find its speed when $I_A = 200$ A.
 (c) If the motor is differentially compounded, find its speed when $I_A = 200$ A.

Solution

- (a) At no load, the armature current is zero, so the internal generated voltage of the motor must equal V_T , which means that it must be 250 V. From the magnetization curve, a field current of 5 A will produce a voltage E_A of 250 V at 1200 r/min. Therefore, the shunt field current must be 5 A.
 (b) When an armature current of 200 A flows in the motor, the machine's internal generated voltage is

$$\begin{aligned} E_A &= V_T - I_A(R_A + R_S) \\ &= 250 \text{ V} - (200 \text{ A})(0.04 \Omega) = 242 \text{ V} \end{aligned}$$

The effective field current of this cumulatively compounded motor is

$$\begin{aligned} I_F^* &= I_F + \frac{N_{SE}}{N_F} I_A - \frac{\mathcal{F}_{AR}}{N_F} \\ &= 5 \text{ A} + \frac{3}{1000} 200 \text{ A} = 5.6 \text{ A} \end{aligned} \quad (9-28)$$

From the magnetization curve, $E_{A0} = 262$ V at speed $n_0 = 1200$ r/min. Therefore, the motor's speed will be

$$\begin{aligned} n &= \frac{E_A}{E_{A0}} n_0 \\ &= \frac{242 \text{ V}}{262 \text{ V}} 1200 \text{ r/min} = 1108 \text{ r/min} \end{aligned}$$

- (c) If the machine is differentially compounded, the effective field current is

$$\begin{aligned} I_F^* &= I_F - \frac{N_{SE}}{N_F} I_A - \frac{\mathcal{F}_{AR}}{N_F} \\ &= 5 \text{ A} - \frac{3}{1000} 200 \text{ A} = 4.4 \text{ A} \end{aligned} \quad (9-28)$$

From the magnetization curve, $E_{A0} = 236$ V at speed $n_0 = 1200$ r/min. Therefore, the motor's speed will be

$$\begin{aligned} n &= \frac{E_A}{E_{A0}} n_0 \\ &= \frac{242 \text{ V}}{236 \text{ V}} 1200 \text{ r/min} = 1230 \text{ r/min} \end{aligned}$$

Notice that the speed of the cumulatively compounded motor decreases with load, while the speed of the differentially compounded motor increases with load.

Speed Control in the Cumulatively Compounded DC Motor

The techniques available for the control of speed in a cumulatively compounded dc motor are the same as those available for a shunt motor:

1. Change the field resistance R_F .
2. Change the armature voltage V_A .
3. Change the armature resistance R_A .

The arguments describing the effects of changing R_F or V_A are very similar to the arguments given earlier for the shunt motor.

Theoretically, the differentially compounded dc motor could be controlled in a similar manner. Since the differentially compounded motor is almost never used, that fact hardly matters.

9.8 DC MOTOR STARTERS

In order for a dc motor to function properly on the job, it must have some special control and protection equipment associated with it. The purposes of this equipment are

1. To protect the motor against damage due to short circuits in the equipment
2. To protect the motor against damage from long-term overloads
3. To protect the motor against damage from excessive starting currents
4. To provide a convenient manner in which to control the operating speed of the motor

The first three functions will be discussed in this section, and the fourth function will be considered in Section 9.9.

DC Motor Problems on Starting

In order for a dc motor to function properly, it must be protected from physical damage during the starting period. At starting conditions, the motor is not turning, and so $E_A = 0$ V. Since the internal resistance of a normal dc motor is very low

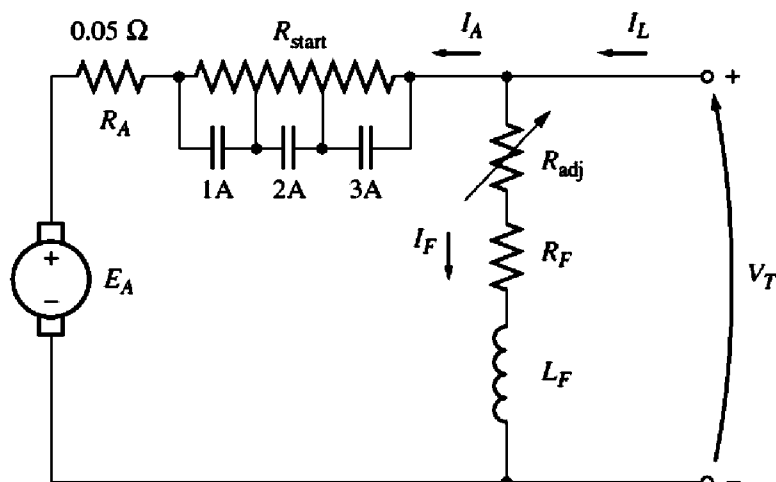

FIGURE 9-28

A shunt motor with a starting resistor in series with its armature. Contacts 1A, 2A, and 3A short-circuit portions of the starting resistor when they close.

compared to its size (3 to 6 percent per unit for medium-size motors), a *very* high current flows.

Consider, for example, the 50-hp, 250-V motor in Example 9-1. This motor has an armature resistance R_A of $0.06\ \Omega$, and a full-load current less than 200 A, but the current on starting is

$$\begin{aligned} I_A &= \frac{V_T - E_A}{R_A} \\ &= \frac{250\ \text{V} - 0\ \text{V}}{0.06\ \Omega} = 4167\ \text{A} \end{aligned}$$

This current is over 20 times the motor's rated full-load current. It is possible for a motor to be severely damaged by such currents, even if they last for only a moment.

A solution to the problem of excess current during starting is to insert a *starting resistor* in series with the armature to limit the current flow until E_A can build up to do the limiting. This resistor must not be in the circuit permanently, because it would result in excessive losses and would cause the motor's torque-speed characteristic to drop off excessively with an increase in load.

Therefore, a resistor must be inserted into the armature circuit to limit current flow at starting, and it must be removed again as the speed of the motor builds up. In modern practice, a starting resistor is made up of a series of pieces, each of which is removed from the motor circuit in succession as the motor speeds up, in order to limit the current in the motor to a safe value while never reducing it to too low a value for rapid acceleration.

Figure 9-28 shows a shunt motor with an extra starting resistor that can be cut out of the circuit in segments by the closing of the 1A, 2A, and 3A contacts. Two actions are necessary in order to make a working motor starter. The first is to pick the size and number of resistor segments necessary in order to limit the starting current to its desired bounds. The second is to design a control circuit that

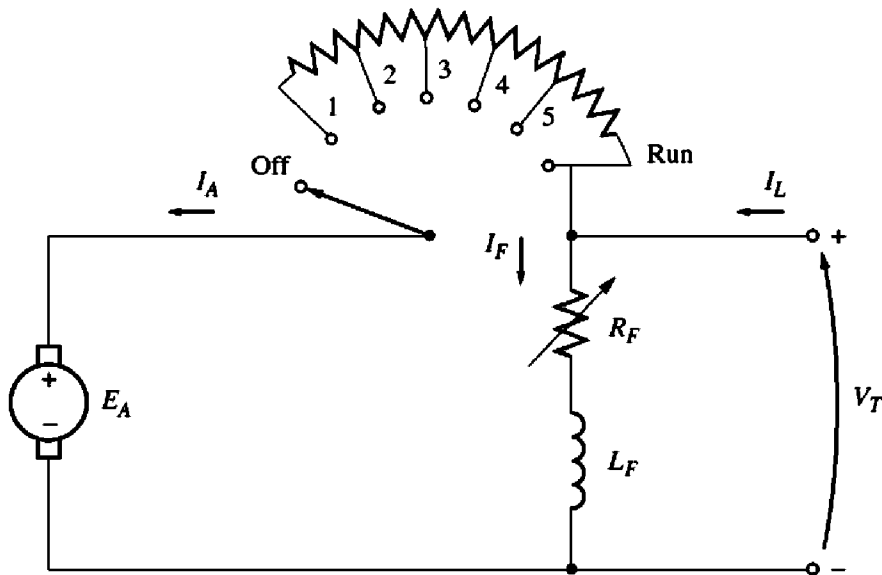

FIGURE 9–29
A manual dc motor starter.

shuts the resistor bypass contacts at the proper time to remove those parts of the resistor from the circuit.

Some older dc motor starters used a continuous starting resistor which was gradually cut out of the circuit by a person moving its handle (Figure 9–29). This type of starter had problems, as it largely depended on the person starting the motor not to move its handle too quickly or too slowly. If the resistance were cut out too quickly (before the motor could speed up enough), the resulting current flow would be too large. On the other hand, if the resistance were cut out too slowly, the starting resistor could burn up. Since they depended on a person for their correct operation, these motor starters were subject to the problem of human error. They have almost entirely been displaced in new installations by automatic starter circuits.

Example 9–7 illustrates the selection of the size and number of resistor segments needed by an automatic starter circuit. The question of the timing required to cut the resistor segments out of the armature circuit will be examined later.

Example 9–7. Figure 9–28 shows a 100-hp, 250-V, 350-A shunt dc motor with an armature resistance of $0.05\ \Omega$. It is desired to design a starter circuit for this motor which will limit the maximum starting current to *twice* its rated value and which will switch out sections of resistance as the armature current falls to its rated value.

- How many stages of starting resistance will be required to limit the current to the range specified?
- What must the value of each segment of the resistor be? At what voltage should each stage of the starting resistance be cut out?

Solution

- The starting resistor must be selected so that the current flow equals twice the rated current of the motor when it is first connected to the line. As the motor starts to speed up, an internal generated voltage E_A will be produced in the

motor. Since this voltage opposes the terminal voltage of the motor, the increasing internal generated voltage decreases the current flow in the motor. When the current flowing in the motor falls to rated current, a section of the starting resistor must be taken out to increase the starting current back up to 200 percent of rated current. As the motor continues to speed up, E_A continues to rise and the armature current continues to fall. When the current flowing in the motor falls to rated current again, another section of the starting resistor must be taken out. This process repeats until the starting resistance to be removed at a given stage is less than the resistance of the motor's armature circuit. At that point, the motor's armature resistance will limit the current to a safe value all by itself.

How many steps are required to accomplish the current limiting? To find out, define R_{tot} as the original resistance in the starting circuit. So R_{tot} is the sum of the resistance of each stage of the starting resistor together with the resistance of the armature circuit of the motor:

$$R_{\text{tot}} = R_1 + R_2 + \cdots + R_A \quad (9-29)$$

Now define $R_{\text{tot},i}$ as the total resistance left in the starting circuit after stages 1 to i have been shorted out. The resistance left in the circuit after removing stages 1 through i is

$$R_{\text{tot},i} = R_{i+1} + \cdots + R_A \quad (9-30)$$

Note also that the initial starting resistance must be

$$R_{\text{tot}} = \frac{V_T}{I_{\text{max}}}$$

In the first stage of the starter circuit, resistance R_1 must be switched out of the circuit when the current I_A falls to

$$I_A = \frac{V_T - E_A}{R_{\text{tot}}} = I_{\text{min}}$$

After switching that part of the resistance out, the armature current must jump to

$$I_A = \frac{V_T - E_A}{R_{\text{tot},1}} = I_{\text{max}}$$

Since $E_A (= K\phi\omega)$ is directly proportional to the speed of the motor, which cannot change instantaneously, the quantity $V_T - E_A$ must be constant at the instant the resistance is switched out. Therefore,

$$I_{\text{min}}R_{\text{tot}} = V_T - E_A = I_{\text{max}}R_{\text{tot},1}$$

or the resistance left in the circuit after the first stage is switched out is

$$R_{\text{tot},1} = \frac{I_{\text{min}}}{I_{\text{max}}} R_{\text{tot}} \quad (9-31)$$

By direct extension, the resistance left in the circuit after the n th stage is switched out is

$$R_{\text{tot},n} = \left(\frac{I_{\text{min}}}{I_{\text{max}}}\right)^n R_{\text{tot}} \quad (9-32)$$

The starting process is completed when $R_{\text{tot},n}$ for stage n is less than or equal to the internal armature resistance R_A of the motor. At that point, R_A can limit the current to the desired value all by itself. At the boundary where $R_A = R_{\text{tot},n}$

$$R_A = R_{\text{tot},n} = \left(\frac{I_{\min}}{I_{\max}}\right)^n R_{\text{tot}} \quad (9-33)$$

$$\frac{R_A}{R_{\text{tot}}} = \left(\frac{I_{\min}}{I_{\max}}\right)^n \quad (9-34)$$

Solving for n yields

$$n = \frac{\log(R_A/R_{\text{tot}})}{\log(I_{\min}/I_{\max})} \quad (9-35)$$

where n must be rounded up to the next integer value, since it is not possible to have a fractional number of starting stages. If n has a fractional part, then when the final stage of starting resistance is removed, the armature current of the motor will jump up to a value smaller than I_{\max} .

In this particular problem, the ratio $I_{\min}/I_{\max} = 0.5$, and R_{tot} is

$$R_{\text{tot}} = \frac{V_T}{I_{\max}} = \frac{250 \text{ V}}{700 \text{ A}} = 0.357 \Omega$$

so

$$n = \frac{\log(R_A/R_{\text{tot}})}{\log(I_{\min}/I_{\max})} = \frac{\log(0.05 \Omega/0.357 \Omega)}{\log(350 \text{ A}/700 \text{ A})} = 2.84$$

The number of stages required will be three.

- (b) The armature circuit will contain the armature resistor R_A and three starting resistors R_1 , R_2 , and R_3 . This arrangement is shown in Figure 9-28.

At first, $E_A = 0 \text{ V}$ and $I_A = 700 \text{ A}$, so

$$I_A = \frac{V_T}{R_A + R_1 + R_2 + R_3} = 700 \text{ A}$$

Therefore, the total resistance must be

$$R_A + R_1 + R_2 + R_3 = \frac{250 \text{ V}}{700 \text{ A}} = 0.357 \Omega \quad (9-36)$$

This total resistance will be placed in the circuit until the current falls to 350 A. This occurs when

$$E_A = V_T - I_A R_{\text{tot}} = 250 \text{ V} - (350 \text{ A})(0.357 \Omega) = 125 \text{ V}$$

When $E_A = 125 \text{ V}$, I_A has fallen to 350 A and it is time to cut out the first starting resistor R_1 . When it is cut out, the current should jump back to 700 A. Therefore,

$$R_A + R_2 + R_3 = \frac{V_T - E_A}{I_{\max}} = \frac{250 \text{ V} - 125 \text{ V}}{700 \text{ A}} = 0.1786 \Omega \quad (9-37)$$

This total resistance will be in the circuit until I_A again falls to 350 A. This occurs when E_A reaches

$$E_A = V_T - I_A R_{\text{tot}} = 250 \text{ V} - (350 \text{ A})(0.1786 \Omega) = 187.5 \text{ V}$$

When $E_A = 187.5$ V, I_A has fallen to 350 A and it is time to cut out the second starting resistor R_2 . When it is cut out, the current should jump back to 700 A. Therefore,

$$R_A + R_3 = \frac{V_T - E_A}{I_{\max}} = \frac{250 \text{ V} - 187.5 \text{ V}}{700 \text{ A}} = 0.0893 \Omega \quad (9-38)$$

This total resistance will be in the circuit until I_A again falls to 350 A. This occurs when E_A reaches

$$E_A = V_T - I_A R_{\text{tot}} = 250 \text{ V} - (350 \text{ A})(0.0893 \Omega) = 218.75 \text{ V}$$

When $E_A = 218.75$ V, I_A has fallen to 350 A and it is time to cut out the third starting resistor R_3 . When it is cut out, only the internal resistance of the motor is left. By now, though, R_A alone can limit the motor's current to

$$\begin{aligned} I_A &= \frac{V_T - E_A}{R_A} = \frac{250 \text{ V} - 218.75 \text{ V}}{0.05 \Omega} \\ &= 625 \text{ A} \quad (\text{less than allowed maximum}) \end{aligned}$$

From this point on, the motor can speed up by itself.

From Equations (9-34) to (9-36), the required resistor values can be calculated:

$$R_3 = R_{\text{tot},3} - R_A = 0.0893 \Omega - 0.05 \Omega = 0.0393 \Omega$$

$$R_2 = R_{\text{tot},2} - R_3 - R_A = 0.1786 \Omega - 0.0393 \Omega - 0.05 \Omega = 0.0893 \Omega$$

$$R_1 = R_{\text{tot},1} - R_2 - R_3 - R_A = 0.357 \Omega - 0.1786 \Omega - 0.0393 \Omega - 0.05 \Omega = 0.1786 \Omega$$

And R_1 , R_2 , and R_3 are cut out when E_A reaches 125, 187.5, and 218.75 V, respectively.

DC Motor Starting Circuits

Once the starting resistances have been selected, how can their shorting contacts be controlled to ensure that they shut at exactly the correct moment? Several different schemes are used to accomplish this switching, and two of the most common approaches will be examined in this section. Before that is done, though, it is necessary to introduce some of the components used in motor-starting circuits.

Figure 9-30 illustrates some of the devices commonly used in motor-control circuits. The devices illustrated are fuses, push button switches, relays, time delay relays, and overloads.

Figure 9-30a shows a symbol for a fuse. The fuses in a motor-control circuit serve to protect the motor against the danger of short circuits. They are placed in the power supply lines leading to motors. If a motor develops a short circuit, the fuses in the line leading to it will burn out, opening the circuit before any damage has been done to the motor itself.

Figure 9-30b shows spring-type push button switches. There are two basic types of such switches—normally open and normally shut. *Normally open* contacts are open when the button is resting and closed when the button has been

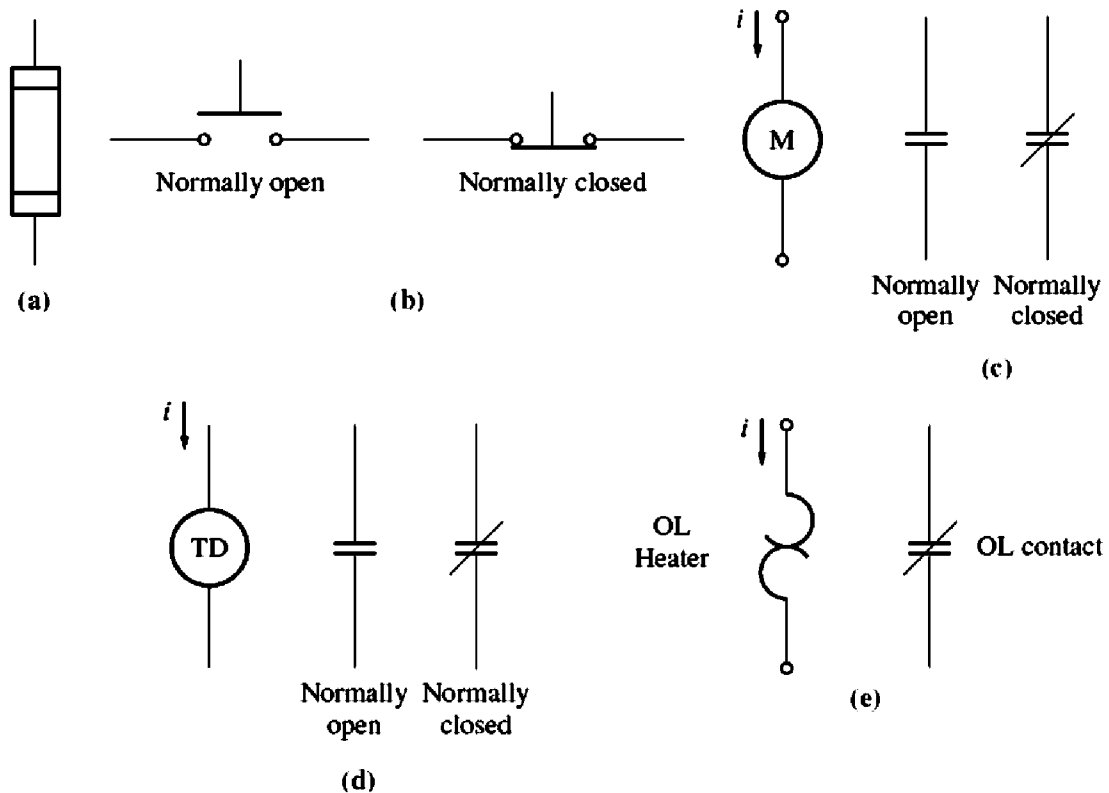
**FIGURE 9-30**

(a) A fuse. (b) Normally open and normally closed push button switches. (c) A relay coil and contacts. (d) A time delay relay and contacts. (e) An overload and its normally closed contacts.

pushed, while *normally closed* contacts are closed when the button is resting and open when the button has been pushed.

A relay is shown in Figure 9-30c. It consists of a main coil and a number of contacts. The main coil is symbolized by a circle, and the contacts are shown as parallel lines. The contacts are of two types—normally open and normally closed. A *normally open* contact is one which is open when the relay is deenergized, and a *normally closed* contact is one which is closed when the relay is deenergized. When electric power is applied to the relay (the relay is energized), its contacts change state: The normally open contacts close, and the normally closed contacts open.

A time delay relay is shown in Figure 9-30d. It behaves exactly like an ordinary relay except that when it is energized there is an adjustable time delay before its contacts change state.

An overload is shown in Figure 9-30e. It consists of a heater coil and some normally shut contacts. The current flowing to a motor passes through the heater coils. If the load on a motor becomes too large, then the current flowing to the motor will heat up the heater coils, which will cause the normally shut contacts of the overload to open. These contacts can in turn activate some types of motor protection circuitry.

One common motor-starting circuit using these components is shown in Figure 9-31. In this circuit, a series of time delay relays shut contacts which remove each section of the starting resistor at approximately the correct time after power is

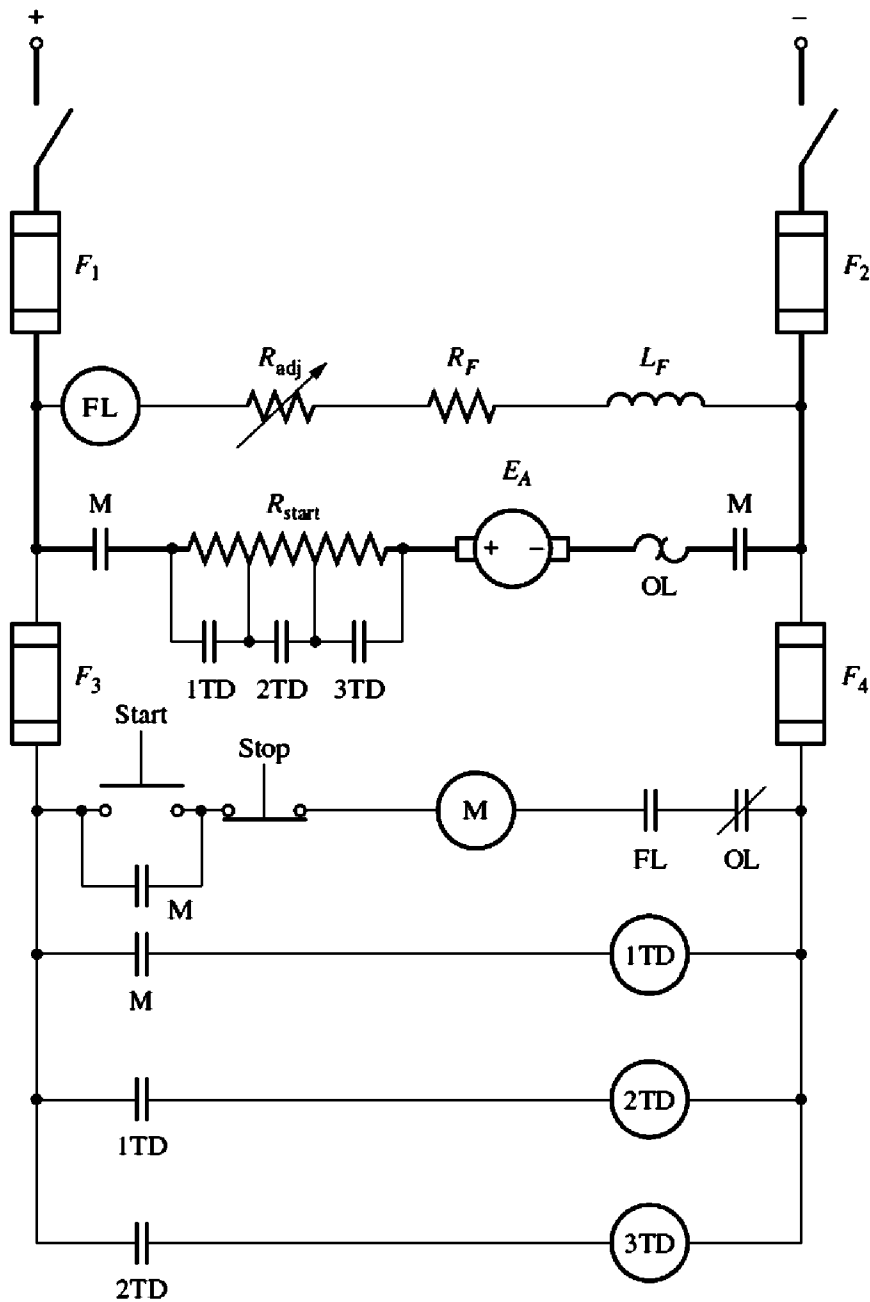

FIGURE 9-31

A dc motor starting circuit rising time delay relays to cut out the starting resistor.

applied to the motor. When the start button is pushed in this circuit, the motor's armature circuit is connected to its power supply, and the machine starts with all resistance in the circuit. However, relay 1TD energizes at the same time as the motor starts, so after some delay the 1TD contacts will shut and remove part of the starting resistance from the circuit. Simultaneously, relay 2TD is energized, so after another time delay the 2TD contacts will shut and remove the second part of the timing resistor. When the 2TD contacts shut, the 3TD relay is energized, so the process repeats again, and finally the motor runs at full speed with no starting resistance present in its circuit. If the time delays are picked properly, the starting resistors can be cut out at just the right times to limit the motor's current to its design values.

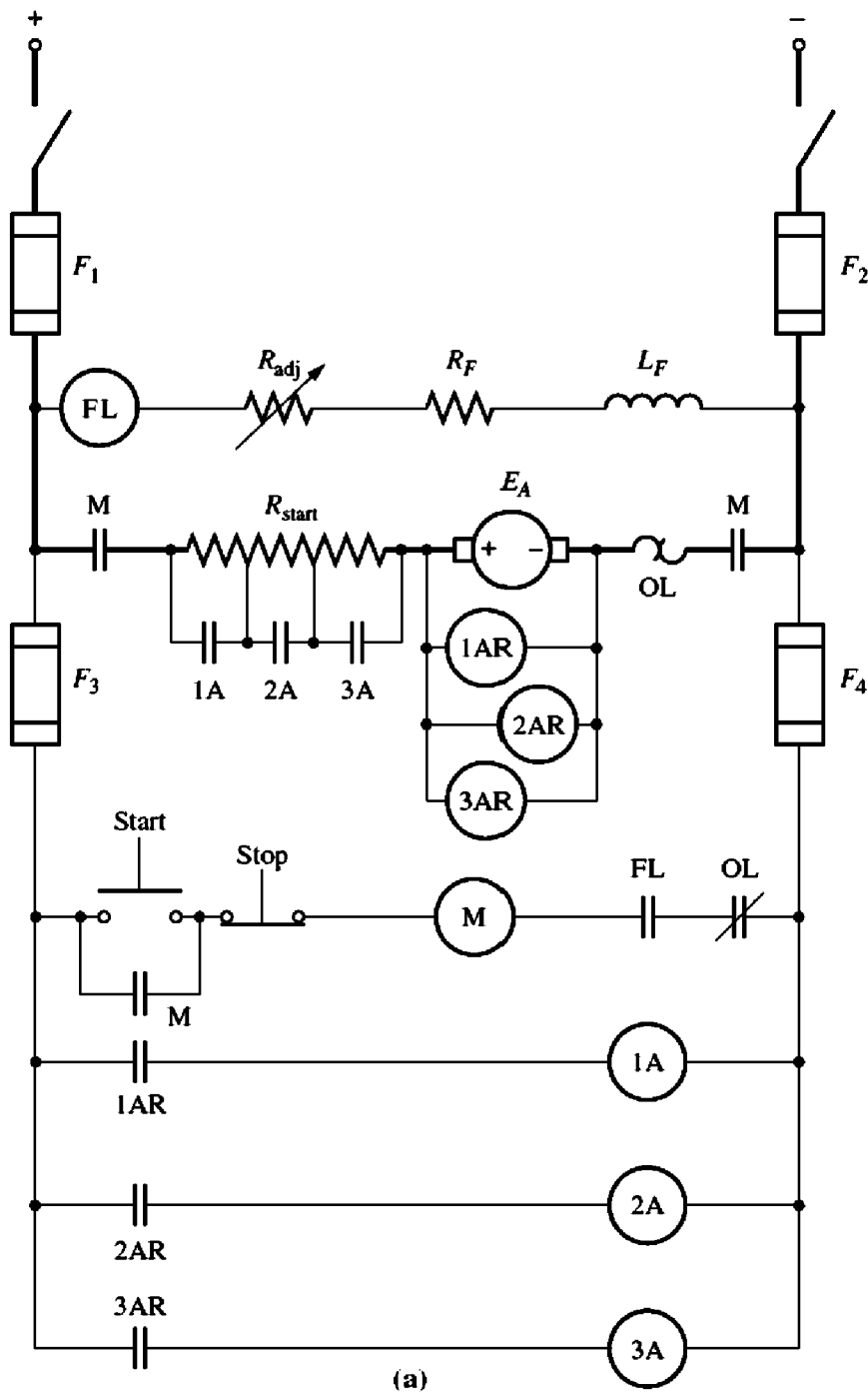
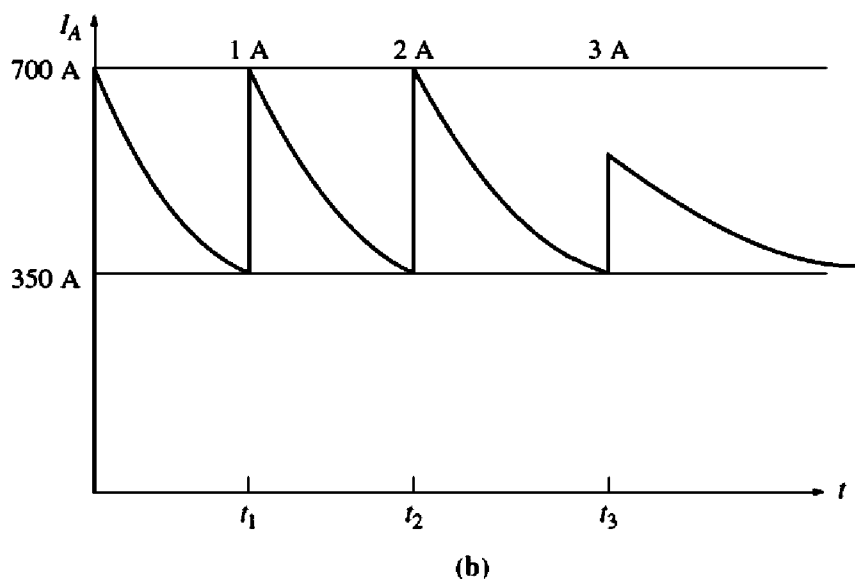

FIGURE 9-32

(a) A dc motor starting circuit using countervoltage-sensing relays to cut out the starting resistor.

Another type of motor starter is shown in Figure 9-32. Here, a series of relays sense the value of E_A in the motor and cut out the starting resistance as E_A rises to preset levels. This type of starter is better than the previous one, since if the motor is loaded heavily and starts more slowly than normal, its armature resistance is still cut out when its current falls to the proper value.

Notice that both starter circuits have a relay in the field circuit labeled FL. This is a *field loss relay*. If the field current is lost for any reason, the field loss

**FIGURE 9–32 (concluded)**

(b) The armature current in a dc motor during starting.

relay is deenergized, which turns off power to the M relay. When the M relay deenergizes, its normally open contacts open and disconnect the motor from the power supply. This relay prevents the motor from running away if its field current is lost.

Notice also that there is an overload in each motor-starter circuit. If the power drawn from the motor becomes excessive, these overloads will heat up and open the OL normally shut contacts, thus turning off the M relay. When the M relay deenergizes, its normally open contacts open and disconnect the motor from the power supply, so the motor is protected against damage from prolonged excessive loads.

9.9 THE WARD-LEONARD SYSTEM AND SOLID-STATE SPEED CONTROLLERS

The speed of a separately excited, shunt, or compounded dc motor can be varied in one of three ways: by changing the field resistance, changing the armature voltage, or changing the armature resistance. Of these methods, perhaps the most useful is armature voltage control, since it permits wide speed variations without affecting the motor's maximum torque.

A number of motor-control systems have been developed over the years to take advantage of the high torques and variable speeds available from the armature voltage control of dc motors. In the days before solid-state electronic components became available, it was difficult to produce a varying dc voltage. In fact, the normal way to vary the armature voltage of a dc motor was to provide it with its own separate dc generator.

An armature voltage control system of this sort is shown in Figure 9–33. This figure shows an ac motor serving as a prime mover for a dc generator, which

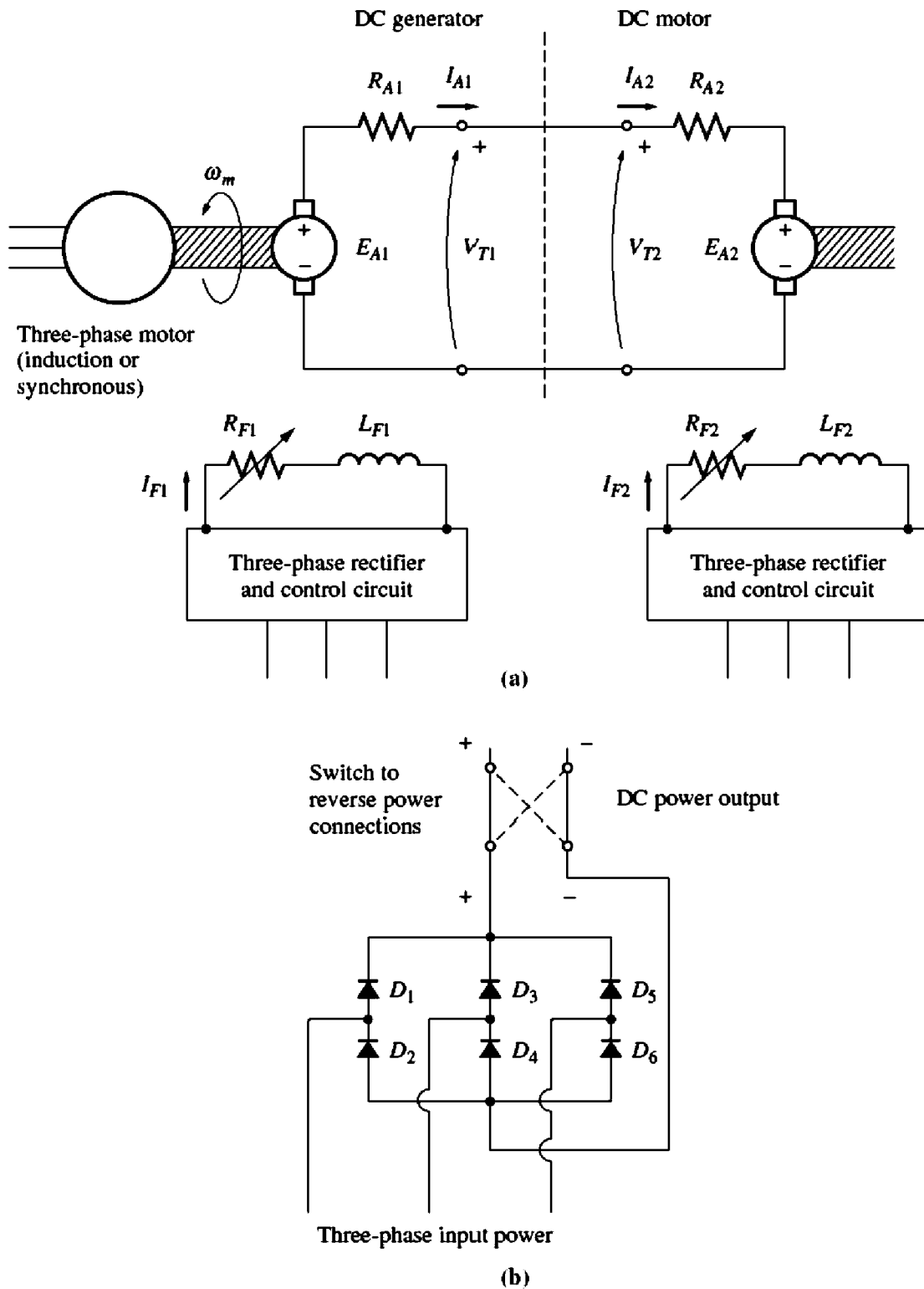

FIGURE 9-33

(a) A Ward-Leonard system for dc motor speed control. (b) The circuit for producing field current in the dc generator and dc motor.

in turn is used to supply a dc voltage to a dc motor. Such a system of machines is called a *Ward-Leonard system*, and it is extremely versatile.

In such a motor-control system, the armature voltage of the motor can be controlled by varying the field current of the dc generator. This armature voltage

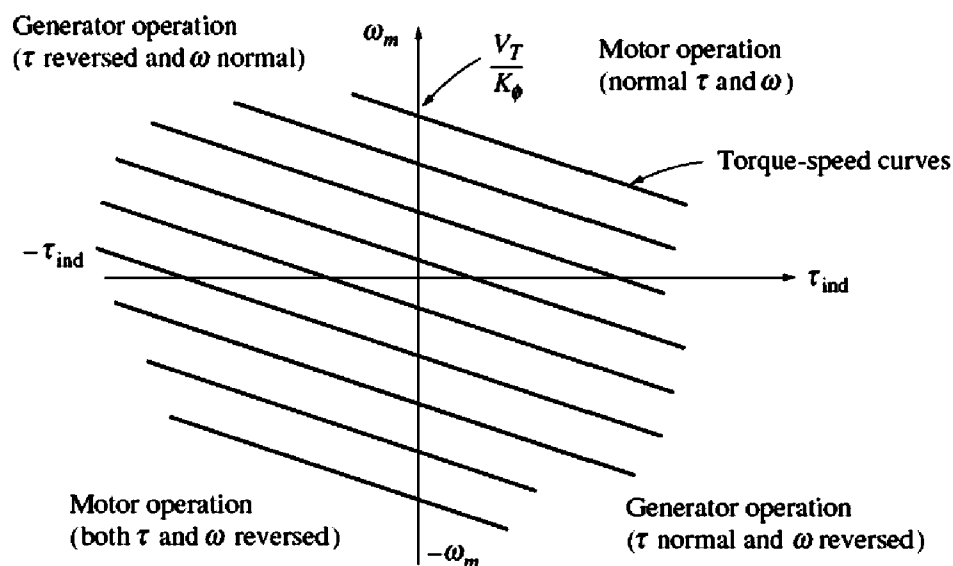

FIGURE 9-34

The operating range of a Ward-Leonard motor-control system. The motor can operate as a motor in either the forward (quadrant 1) or reverse (quadrant 3) direction and it can also regenerate in quadrants 2 and 4.

allows the motor's speed to be smoothly varied between a very small value and the base speed. The speed of the motor can be adjusted above the base speed by reducing the motor's field current. With such a flexible arrangement, total motor speed control is possible.

Furthermore, if the field current of the generator is reversed, then the polarity of the generator's armature voltage will be reversed, too. This will reverse the motor's direction of rotation. Therefore, it is possible to get a very wide range of speed variations *in either direction of rotation* out of a Ward-Leonard dc motor-control system.

Another advantage of the Ward-Leonard system is that it can "regenerate," or return the machine's energy of motion to the supply lines. If a heavy load is first raised and then lowered by the dc motor of a Ward-Leonard system, when the load is falling, the dc motor acts as a generator, supplying power back to the power system. In this fashion, much of the energy required to lift the load in the first place can be recovered, reducing the machine's overall operating costs.

The possible modes of operation of the dc machine are shown in the torque-speed diagram in Figure 9-34. When this motor is rotating in its normal direction and supplying a torque in the direction of rotation, it is operating in the first quadrant of this figure. If the generator's field current is reversed, that will reverse the terminal voltage of the generator, in turn reversing the motor's armature voltage. When the armature voltage reverses with the motor field current remaining unchanged, both the torque and the speed of the motor are reversed, and the machine is operating as a motor in the third quadrant of the diagram. If the torque or the speed alone of the motor reverses while the other quantity does not, then the machine serves as a generator, returning power to the dc power system. Because

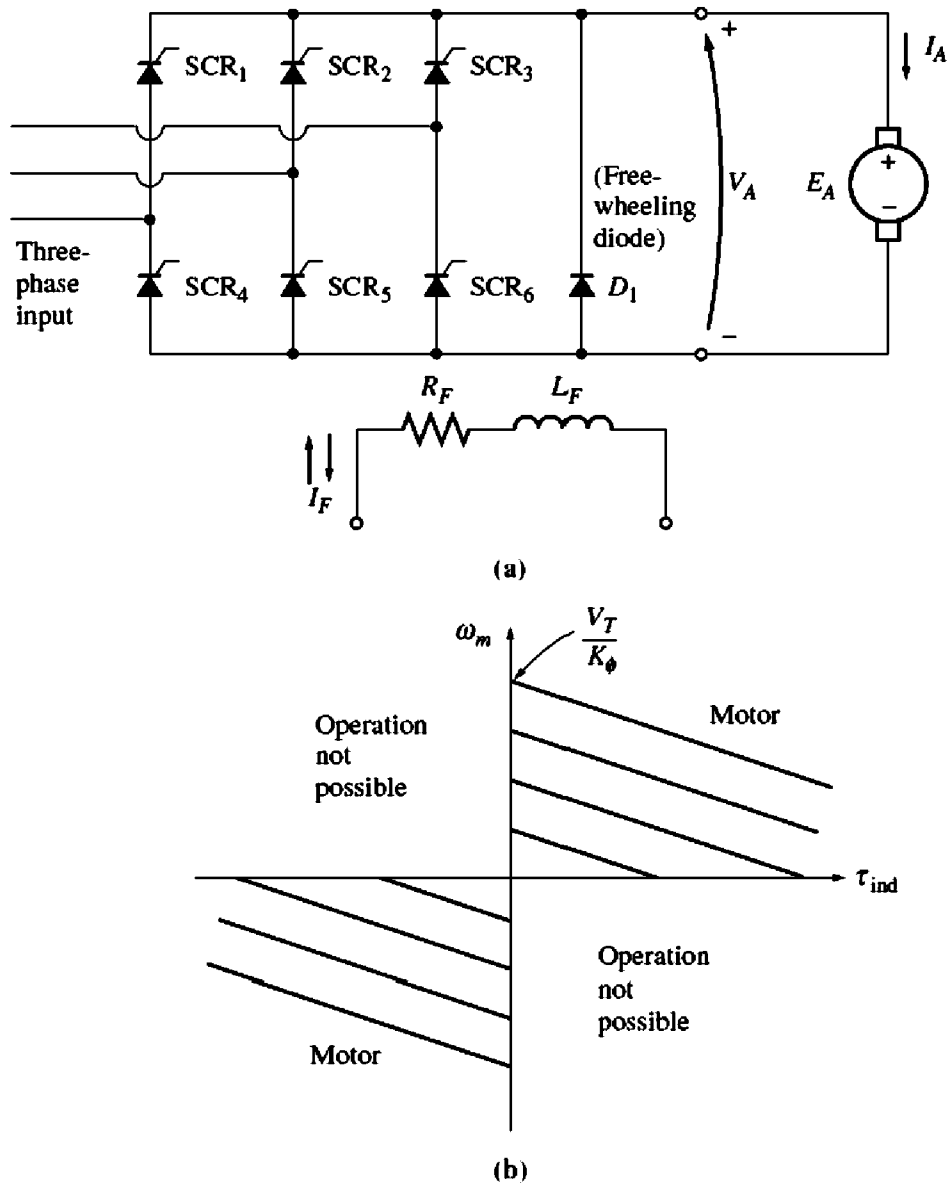
FIGURE 9-35

(a) A two-quadrant solid-state dc motor controller. Since current cannot flow out of the positive terminals of the armature, this motor cannot act as a generator, returning power to the system.

(b) The possible operating quadrants of this motor controller.

a Ward-Leonard system permits rotation and regeneration in either direction, it is called a *four-quadrant control system*.

The disadvantages of a Ward-Leonard system should be obvious. One is that the user is forced to buy *three* full machines of essentially equal ratings, which is quite expensive. Another is that three machines will be much less efficient than one. Because of its expense and relatively low efficiency, the Ward-Leonard system has been replaced in new applications by SCR-based controller circuits.

A simple dc armature voltage controller circuit is shown in Figure 9-35. The average voltage applied to the armature of the motor, and therefore the average speed of the motor, depends on the fraction of the time the supply voltage is applied to the armature. This in turn depends on the relative phase at which the

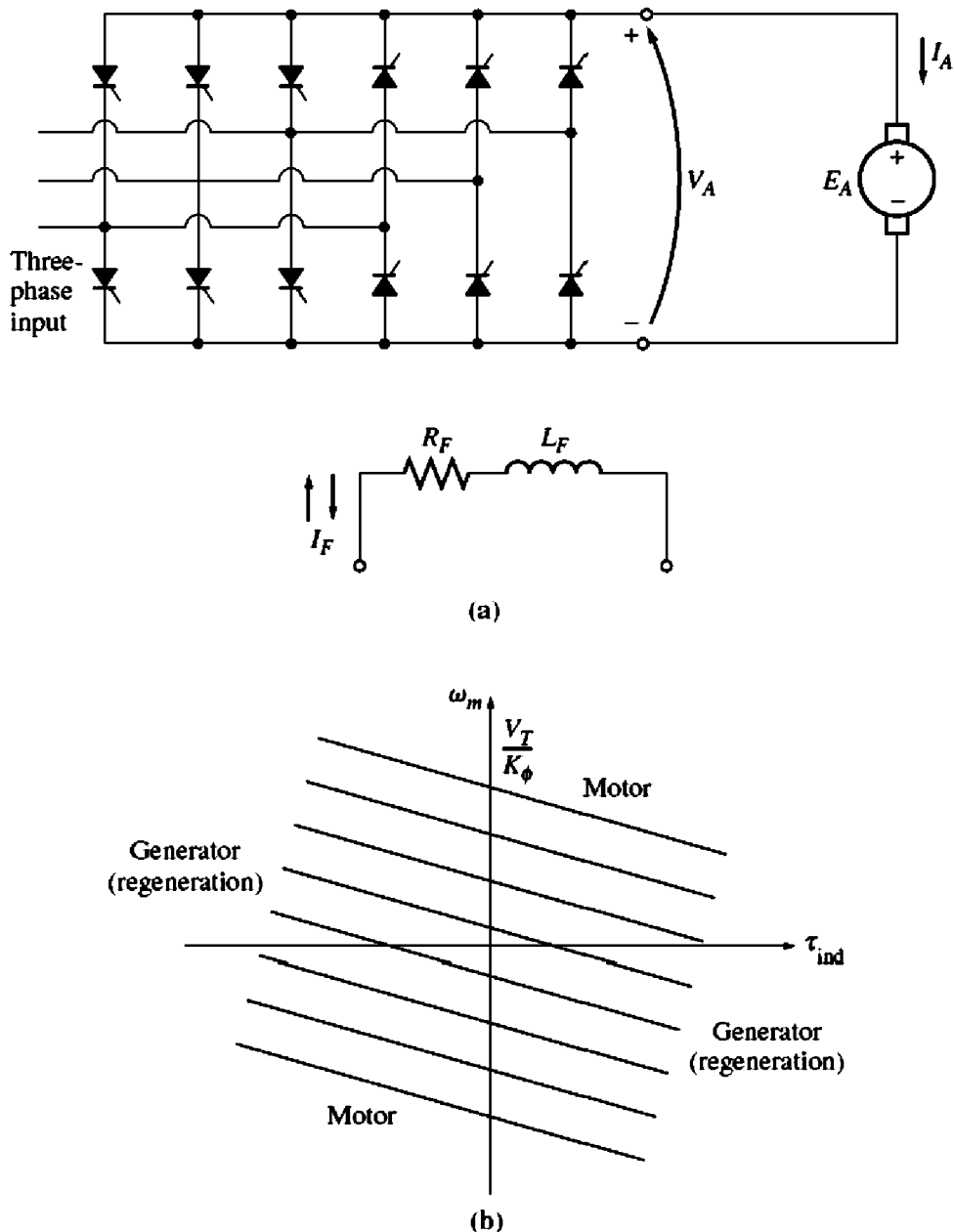
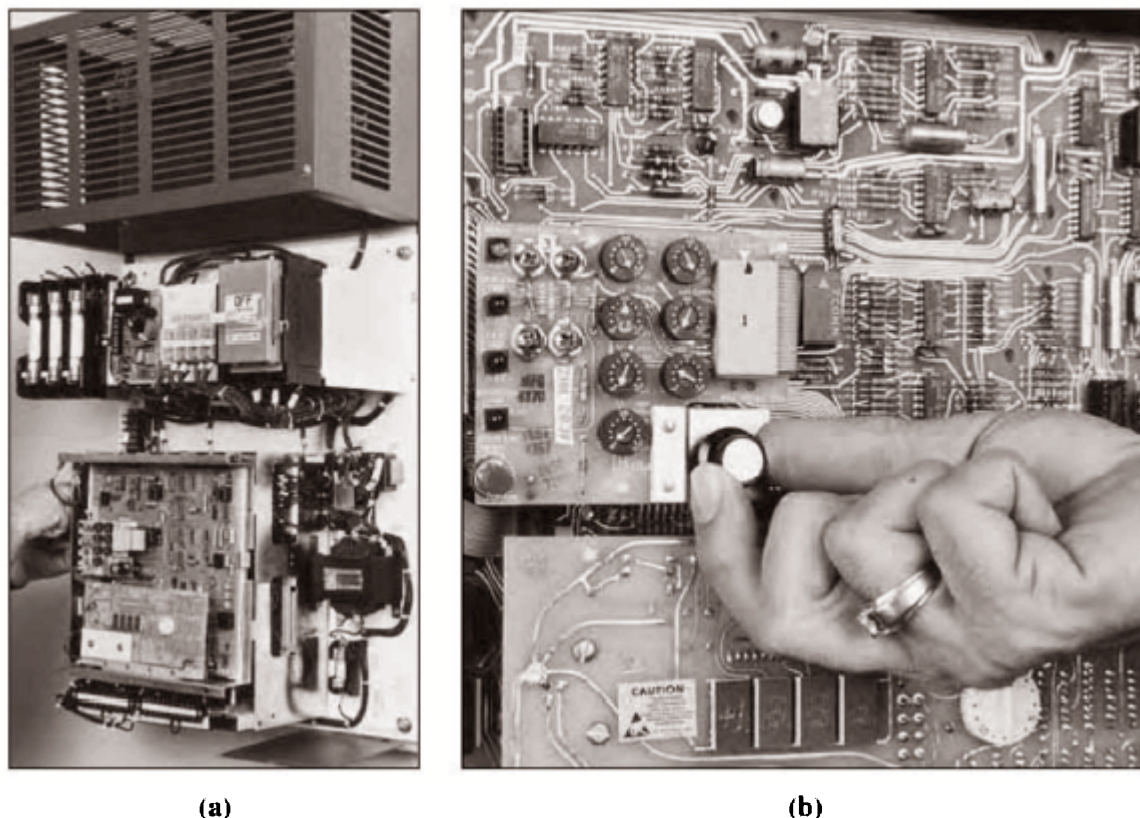

FIGURE 9-36

(a) A four-quadrant solid-state dc motor controller. (b) The possible operating quadrants of this motor controller.

SCRs in the rectifier circuit are triggered. This particular circuit is only capable of supplying an armature voltage with one polarity, so the motor can only be reversed by switching the polarity of its field connection. Notice that it is not possible for an armature current to flow out the positive terminal of this motor, since current cannot flow backward through an SCR. Therefore, this motor *cannot* regenerate, and any energy supplied to the motor cannot be recovered. This type of control circuit is a two-quadrant controller, as shown in Figure 9-35b.

A more advanced circuit capable of supplying an armature voltage with either polarity is shown in Figure 9-36. This armature voltage control circuit can

**FIGURE 9-37**

(a) A typical solid-state shunt dc motor drive. (*Courtesy of MagneTek, Inc.*) (b) A close-up view of the low-power electronics circuit board, showing the adjustments for current limits, acceleration rate, deceleration rate, minimum speed, and maximum speed. (*Courtesy of MagneTek, Inc.*)

permit a current flow out of the positive terminals of the generator, so a motor with this type of controller can regenerate. If the polarity of the motor field circuit can be switched as well, then the solid-state circuit is a full four-quadrant controller like the Ward-Leonard system.

A two-quadrant or a full four-quadrant controller built with SCRs is cheaper than the two extra complete machines needed for the Ward-Leonard system, so solid-state speed-control systems have largely displaced Ward-Leonard systems in new applications.

A typical two-quadrant shunt dc motor drive with armature voltage speed control is shown in Figure 9-37, and a simplified block diagram of the drive is shown in Figure 9-38. This drive has a constant field voltage supplied by a three-phase full-wave rectifier, and a variable armature terminal voltage supplied by six SCRs arranged as a three-phase full-wave rectifier. The voltage supplied to the armature of the motor is controlled by adjusting the firing angle of the SCRs in the bridge. Since this motor controller has a fixed field voltage and a variable armature voltage, it is only able to control the speed of the motor at speeds less than or equal to the base speed (see “Changing the Armature Voltage” in Section 9.4). The controller circuit is identical with that shown in Figure 9-35, except that all of the control electronics and feedback circuits are shown.

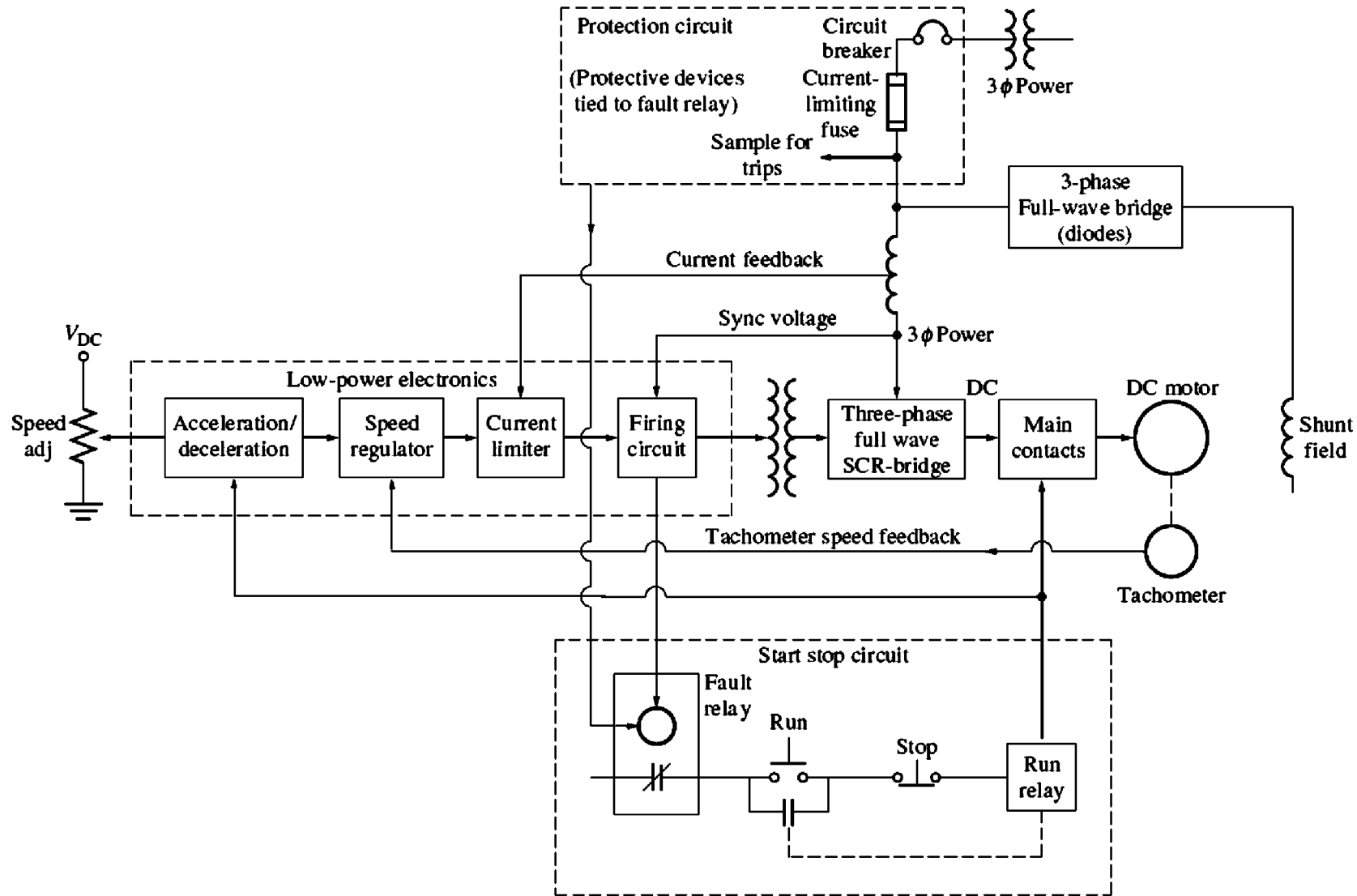

FIGURE 9-38

A simplified block diagram of the typical solid-state shunt dc motor drive shown in Figure 9-37. (Simplified from a block diagram provided by MagneTek, Inc.)

The major sections of this dc motor drive include:

1. A protection circuit section to protect the motor from excessive armature currents, low terminal voltage, and loss of field current.
2. A start/stop circuit to connect and disconnect the motor from the line.
3. A high-power electronics section to convert three-phase ac power to dc power for the motor's armature and field circuits.
4. A low-power electronics section to provide firing pulses to the SCRs which supply the armature voltage to the motor. This section contains several major subsections, which will be described below.

Protection Circuit Section

The protection circuit section combines several different devices which together ensure the safe operation of the motor. Some typical safety devices included in this type of drive are

1. *Current-limiting fuses*, to disconnect the motor quickly and safely from the power line in the event of a short circuit within the motor. Current-limiting fuses can interrupt currents of up to several hundred thousand amperes.
2. An *instantaneous static trip*, which shuts down the motor if the armature current exceeds 300 percent of its rated value. If the armature current exceeds the maximum allowed value, the trip circuit activates the fault relay, which deenergizes the run relay, opening the main contactors and disconnecting the motor from the line.
3. An *inverse-time overload trip*, which guards against sustained overcurrent conditions not great enough to trigger the instantaneous static trip but large enough to damage the motor if allowed to continue indefinitely. The term *inverse time* implies that the higher the overcurrent flowing in the motor, the faster the overload acts (Figure 9–39). For example, an inverse-time trip might take a full minute to trip if the current flow were 150 percent of the rated current of the motor, but take 10 seconds to trip if the current flow were 200 percent of the rated current of the motor.
4. An *undervoltage trip*, which shuts down the motor if the line voltage supplying the motor drops by more than 20 percent.
5. A *field loss trip*, which shuts down the motor if the field circuit is lost.
6. An *overtemperature trip*, which shuts down the motor if it is in danger of overheating.

Start/Stop Circuit Section

The start/stop circuit section contains the controls needed to start and stop the motor by opening or closing the main contacts connecting the motor to the line. The motor is started by pushing the run button, and it is stopped either by pushing the

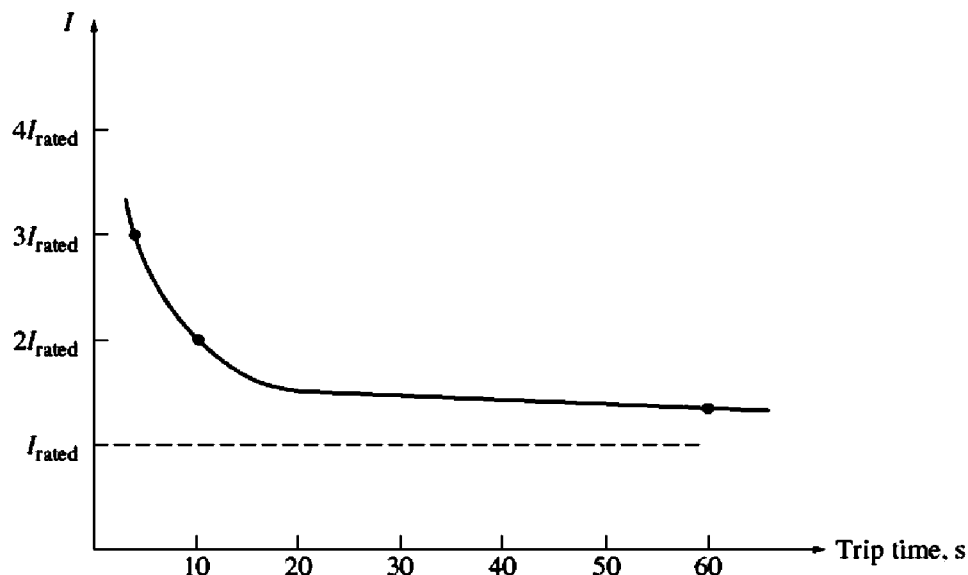

FIGURE 9-39
An inverse-time trip characteristic.

stop button or by energizing the fault relay. In either case, the run relay is deenergized, and the main contacts connecting the motor to the line are opened.

High-Power Electronics Section

The high-power electronics section contains a three-phase full-wave diode rectifier to provide a constant voltage to the field circuit of the motor and a three-phase full-wave SCR rectifier to provide a variable voltage to the armature circuit of the motor.

Low-Power Electronics Section

The low-power electronics section provides firing pulses to the SCRs which supply the armature voltage to the motor. By adjusting the firing time of the SCRs, the low-power electronics section adjusts the motor's average armature voltage. The low-power electronics section contains the following subsystems:

1. *Speed regulation circuit.* This circuit measures the speed of the motor with a tachometer, compares that speed with the desired speed (a reference voltage level), and increases or decreases the armature voltage as necessary to keep the speed constant at the desired value. For example, suppose that the load on the shaft of the motor is increased. If the load is increased, then the motor will slow down. The decrease in speed will reduce the voltage generated by the tachometer, which is fed into the speed regulation circuit. Because the voltage level corresponding to the speed of the motor has fallen below the reference voltage, the speed regulator circuit will advance the firing time of the SCRs, producing a higher armature voltage. The higher armature voltage will tend to increase the speed of the motor back to the desired level (see Figure 9-40).

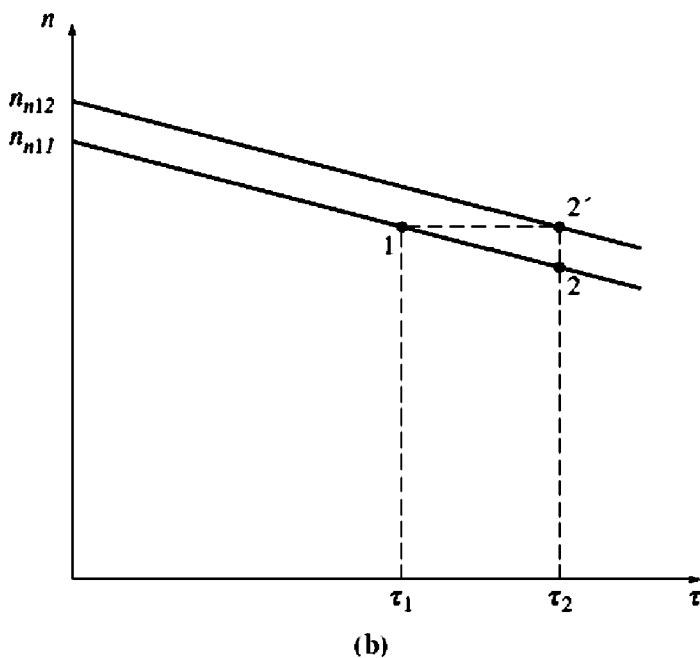
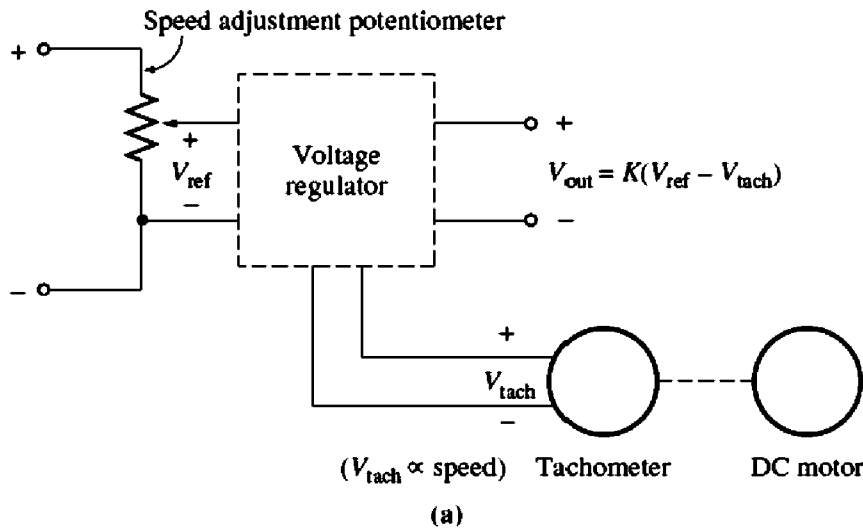
**FIGURE 9-40**

(a) The speed regulator circuit produces an output voltage which is proportional to the difference between the desired speed of the motor (set by V_{ref}) and the actual speed of the motor (measured by V_{tach}). This output voltage is applied to the firing circuit in such a way that the larger the output voltage becomes, the earlier the SCRs in the drive turn on and the higher the average terminal voltage becomes. (b) The effect of increasing load on a shunt dc motor with a speed regulator. The load in the motor is increased. If no regulator were present, the motor would slow down and operate at point 2. When the speed regulator is present, it detects the decrease in speed and boosts the armature voltage of the motor to compensate. This raises the whole torque-speed characteristic curve of the motor, resulting in operation at point 2'.

With proper design, a circuit of this type can provide speed regulations of 0.1 percent between no-load and full-load conditions.

The desired operating speed of the motor is controlled by changing the reference voltage level. The reference voltage level can be adjusted with a small potentiometer, as shown in Figure 9-40.

2. *Current-limiting circuit.* This circuit measures the steady-state current flowing to the motor, compares that current with the desired maximum current (set by a reference voltage level), and decreases the armature voltage as necessary to keep the current from exceeding the desired maximum value. The desired maximum current can be adjusted over a wide range, say from 0 to 200 percent or more of the motor's rated current. This current limit should typically be set at greater than rated current, so that the motor can accelerate under full-load conditions.
3. *Acceleration/deceleration circuit.* This circuit limits the acceleration and deceleration of the motor to a safe value. Whenever a dramatic speed change is commanded, this circuit intervenes to ensure that the transition from the original speed to the new speed is smooth and does not cause an excessive armature current transient in the motor.

The acceleration/deceleration circuit completely eliminates the need for a starting resistor, since starting the motor is just another kind of large speed change, and the acceleration/deceleration circuit acts to cause a smooth increase in speed over time. This gradual smooth increase in speed limits the current flowing in the machine's armature to a safe value.

9.10 DC MOTOR EFFICIENCY CALCULATIONS

To calculate the efficiency of a dc motor, the following losses must be determined:

1. Copper losses
2. Brush drop losses
3. Mechanical losses
4. Core losses
5. Stray losses

The copper losses in the motor are the I^2R losses in the armature and field circuits of the motor. These losses can be found from a knowledge of the currents in the machine and the two resistances. To determine the resistance of the armature circuit in a machine, block its rotor so that it cannot turn and apply a *small* dc voltage to the armature terminals. Adjust that voltage until the current flowing in the armature is equal to the rated armature current of the machine. The ratio of the applied voltage to the resulting armature current flow is R_A . The reason that the current should be about equal to full-load value when this test is done is that R_A varies with temperature, and at the full-load value of the current, the armature windings will be near their normal operating temperature.

The resulting resistance will not be entirely accurate, because

1. The cooling that normally occurs when the motor is spinning will not be present.

2. Since there is an ac voltage in the rotor conductors during normal operation, they suffer from some amount of skin effect, which further raises armature resistance.

IEEE Standard 113 (Reference 5) deals with test procedures for dc machines. It gives a more accurate procedure for determining R_A , which can be used if needed.

The field resistance is determined by supplying the full-rated field voltage to the field circuit and measuring the resulting field current. The field resistance R_F is just the ratio of the field voltage to the field current.

Brush drop losses are often approximately lumped together with copper losses. If they are treated separately, they can be determined from a plot of contact potential versus current for the particular type of brush being used. The brush drop losses are just the product of the brush voltage drop V_{BD} and the armature current I_A .

The core and mechanical losses are usually determined together. If a motor is allowed to turn freely at no load and at rated speed, then there is no output power from the machine. Since the motor is at no load, I_A is very small and the armature copper losses are negligible. Therefore, if the field copper losses are subtracted from the input power of the motor, the remaining input power must consist of the mechanical and core losses of the machine at that speed. These losses are called the *no-load rotational losses* of the motor. As long as the motor's speed remains nearly the same as it was when the losses were measured, the no-load rotational losses are a good estimate of mechanical and core losses under load in the machine.

An example of the determination of a motor's efficiency is given below.

Example 9-8. A 50-hp, 250-V, 1200 r/min shunt dc motor has a rated armature current of 170 A and a rated field current of 5 A. When its rotor is blocked, an armature voltage of 10.2 V (exclusive of brushes) produces 170 A of current flow, and a field voltage of 250 V produces a field current flow of 5 A. The brush voltage drop is assumed to be 2 V. At no load with the terminal voltage equal to 240 V, the armature current is equal to 13.2 A, the field current is 4.8 A, and the motor's speed is 1150 r/min.

- (a) How much power is output from this motor at rated conditions?
- (b) What is the motor's efficiency?

Solution

The armature resistance of this machine is approximately

$$R_A = \frac{10.2 \text{ V}}{170 \text{ A}} = 0.06 \Omega$$

and the field resistance is

$$R_F = \frac{250 \text{ V}}{5 \text{ A}} = 50 \Omega$$

Therefore, at full load the armature I^2R losses are

$$P_A = (170 \text{ A})^2(0.06 \Omega) = 1734 \text{ W}$$

and the field circuit I^2R losses are

$$P_F = (5 \text{ A})^2(50 \Omega) = 1250 \text{ W}$$

The brush losses at full load are given by

$$P_{\text{brush}} = V_{\text{BD}}I_A = (2 \text{ V})(170 \text{ A}) = 340 \text{ W}$$

The rotational losses at full load are essentially equivalent to the rotational losses at no load, since the no-load and full-load speeds of the motor do not differ too greatly. These losses may be ascertained by determining the input power to the armature circuit at no load and assuming that the armature copper and brush drop losses are negligible, meaning that the no-load armature input power is equal to the rotational losses:

$$P_{\text{tot}} = P_{\text{core}} + P_{\text{mech}} = (240 \text{ V})(13.2 \text{ A}) = 3168 \text{ W}$$

(a) The input power of this motor at the rated load is given by

$$P_{\text{in}} = V_T I_L = (250 \text{ V})(175 \text{ A}) = 43,750 \text{ W}$$

Its output power is given by

$$\begin{aligned} P_{\text{out}} &= P_{\text{in}} - P_{\text{brush}} - P_{\text{cu}} - P_{\text{core}} - P_{\text{mech}} - P_{\text{stray}} \\ &= 43,750 \text{ W} - 340 \text{ W} - 1734 \text{ W} - 1250 \text{ W} - 3168 \text{ W} - (0.01)(43,750 \text{ W}) \\ &= 36,820 \text{ W} \end{aligned}$$

where the stray losses are taken to be 1 percent of the input power.

(b) The efficiency of this motor at full load is

$$\begin{aligned} \eta &= \frac{P_{\text{out}}}{P_{\text{in}}} \times 100\% \\ &= \frac{36,820 \text{ W}}{43,750 \text{ W}} \times 100\% = 84.2\% \end{aligned}$$

9.11 INTRODUCTION TO DC GENERATORS

DC generators are dc machines used as generators. As previously pointed out, there is no real difference between a generator and a motor except for the direction of power flow. There are five major types of dc generators, classified according to the manner in which their field flux is produced:

1. *Separately excited generator.* In a separately excited generator, the field flux is derived from a separate power source independent of the generator itself.
2. *Shunt generator.* In a shunt generator, the field flux is derived by connecting the field circuit directly across the terminals of the generator.
3. *Series generator.* In a series generator, the field flux is produced by connecting the field circuit in series with the armature of the generator.
4. *Cumulatively compounded generator.* In a cumulatively compounded generator, both a shunt and a series field are present, and their effects are additive.
5. *Differentially compounded generator.* In a differentially compounded generator, both a shunt and a series field are present, but their effects are subtractive.

These various types of dc generators differ in their terminal (voltage–current) characteristics, and therefore in the applications to which they are suited.

**FIGURE 9-41**

The first practical dc generator. This is an exact duplicate of the “long-legged Mary Ann,” Thomas Edison’s first commercial dc generator, which was built in 1879. It was rated at 5 kW, 100 V, and 1200 r/min. (*Courtesy of General Electric Company.*)

DC generators are compared by their voltages, power ratings, efficiencies, and voltage regulations. *Voltage regulation* (VR) is defined by the equation

$$\text{VR} = \frac{V_{nl} - V_{fl}}{V_{fl}} \times 100\% \quad (9-39)$$

where V_{nl} is the no-load terminal voltage of the generator and V_{fl} is the full-load terminal voltage of the generator. It is a rough measure of the shape of the generator’s voltage–current characteristic—a positive voltage regulation means a drooping characteristic, and a negative voltage regulation means a rising characteristic.

All generators are driven by a source of mechanical power, which is usually called the *prime mover* of the generator. A prime mover for a dc generator may be a steam turbine, a diesel engine, or even an electric motor. Since the speed of the prime mover affects the output voltage of a generator, and since prime movers can vary widely in their speed characteristics, it is customary to compare the voltage regulation and output characteristics of different generators, *assuming constant-speed prime movers*. Throughout this chapter, a generator’s speed will be assumed to be constant unless a specific statement is made to the contrary.

DC generators are quite rare in modern power systems. Even dc power systems such as those in automobiles now use ac generators plus rectifiers to produce dc power.

The equivalent circuit of a dc generator is shown in Figure 9-42, and a simplified version of the equivalent circuit is shown in Figure 9-43. They look similar to the equivalent circuits of a dc motor, except that the direction of current flow and the brush loss are reversed.

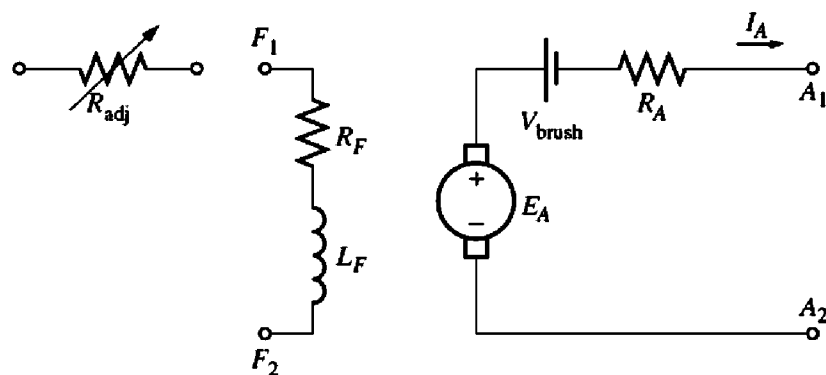

FIGURE 9-42
The equivalent circuit of a dc generator.

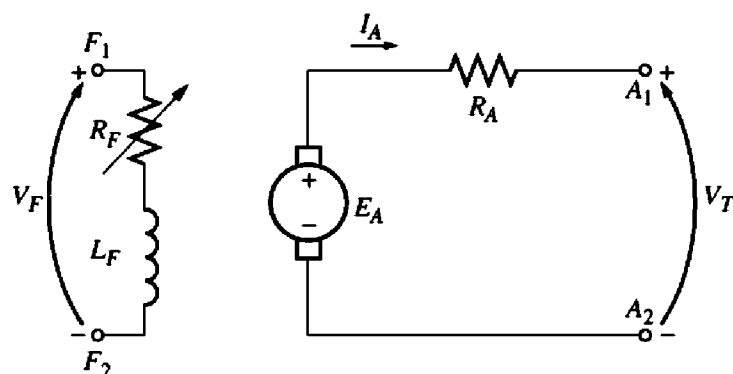

FIGURE 9-43
A simplified equivalent circuit of a dc generator, with R_F combining the resistances of the field coils and the variable control resistor.

9.12 THE SEPARATELY EXCITED GENERATOR

A separately excited dc generator is a generator whose field current is supplied by a separate external dc voltage source. The equivalent circuit of such a machine is shown in Figure 9-44. In this circuit, the voltage V_T represents the actual voltage measured at the terminals of the generator, and the current I_L represents the current flowing in the lines connected to the terminals. The internal generated voltage is E_A , and the armature current is I_A . It is clear that the armature current is equal to the line current in a separately excited generator:

$$I_A = I_L \tag{9-40}$$

The Terminal Characteristic of a Separately Excited DC Generator

The *terminal characteristic* of a device is a plot of the output quantities of the device versus each other. For a dc generator, the output quantities are its terminal voltage and line current. The terminal characteristic of a separately excited generator is

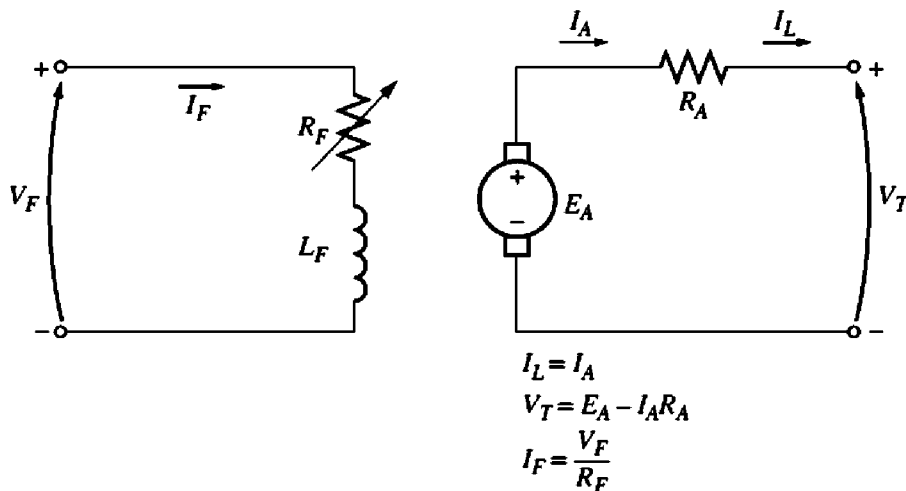

FIGURE 9-44
A separately excited dc generator.

thus a plot of V_T versus I_L for a constant speed ω . By Kirchhoff's voltage law, the terminal voltage is

$$V_T = E_A - I_A R_A \quad (9-41)$$

Since the internal generated voltage is independent of I_A , the terminal characteristic of the separately excited generator is a straight line, as shown in Figure 9-45a.

What happens in a generator of this sort when the load is increased? When the load supplied by the generator is increased, I_L (and therefore I_A) increases. As the armature current increases, the $I_A R_A$ drop increases, so the terminal voltage of the generator falls.

This terminal characteristic is not always entirely accurate. In generators without compensating windings, an increase in I_A causes an increase in armature reaction, and armature reaction causes flux weakening. This flux weakening causes a decrease in $E_A = K\phi\omega$ which further decreases the terminal voltage of the generator. The resulting terminal characteristic is shown in Figure 9-45b. In all future plots, the generators will be assumed to have compensating windings unless stated otherwise. However, it is important to realize that armature reaction can modify the characteristics if compensating windings are not present.

Control of Terminal Voltage

The terminal voltage of a separately excited dc generator can be controlled by changing the internal generated voltage E_A of the machine. By Kirchhoff's voltage law $V_T = E_A - I_A R_A$, so if E_A increases, V_T will increase, and if E_A decreases, V_T will decrease. Since the internal generated voltage E_A is given by the equation $E_A = K\phi\omega$, there are two possible ways to control the voltage of this generator:

1. *Change the speed of rotation.* If ω increases, then $E_A = K\phi\omega \uparrow$ increases, so $V_T = E_A \uparrow - I_A R_A$ increases too.

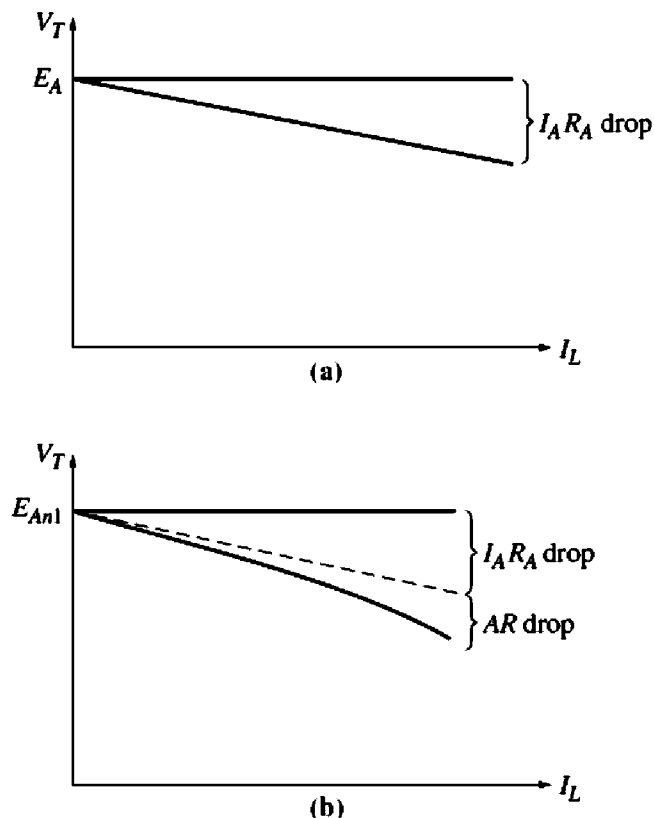

FIGURE 9-45

The terminal characteristic of a separately excited dc generator (a) with and (b) without compensating windings.

2. *Change the field current.* If R_F is decreased, then the field current increases ($I_F = V_F / R_F \uparrow$). Therefore, the flux ϕ in the machine increases. As the flux rises, $E_A = K\phi\omega$ must rise too, so $V_T = E_A - I_A R_A$ increases.

In many applications, the speed range of the prime mover is quite limited, so the terminal voltage is most commonly controlled by changing the field current. A separately excited generator driving a resistive load is shown in Figure 9-46a. Figure 9-46b shows the effect of a decrease in field resistance on the terminal voltage of the generator when it is operating under a load.

Nonlinear Analysis of a Separately Excited DC Generator

Because the internal generated voltage of a generator is a nonlinear function of its magnetomotive force, it is not possible to calculate simply the value of E_A to be expected from a given field current. The magnetization curve of the generator must be used to accurately calculate its output voltage for a given input voltage.

In addition, if a machine has armature reaction, its flux will be reduced with each increase in load, causing E_A to decrease. The only way to accurately determine the output voltage in a machine with armature reaction is to use graphical analysis.

The total magnetomotive force in a separately excited generator is the field circuit magnetomotive force less the magnetomotive force due to armature reaction (AR):

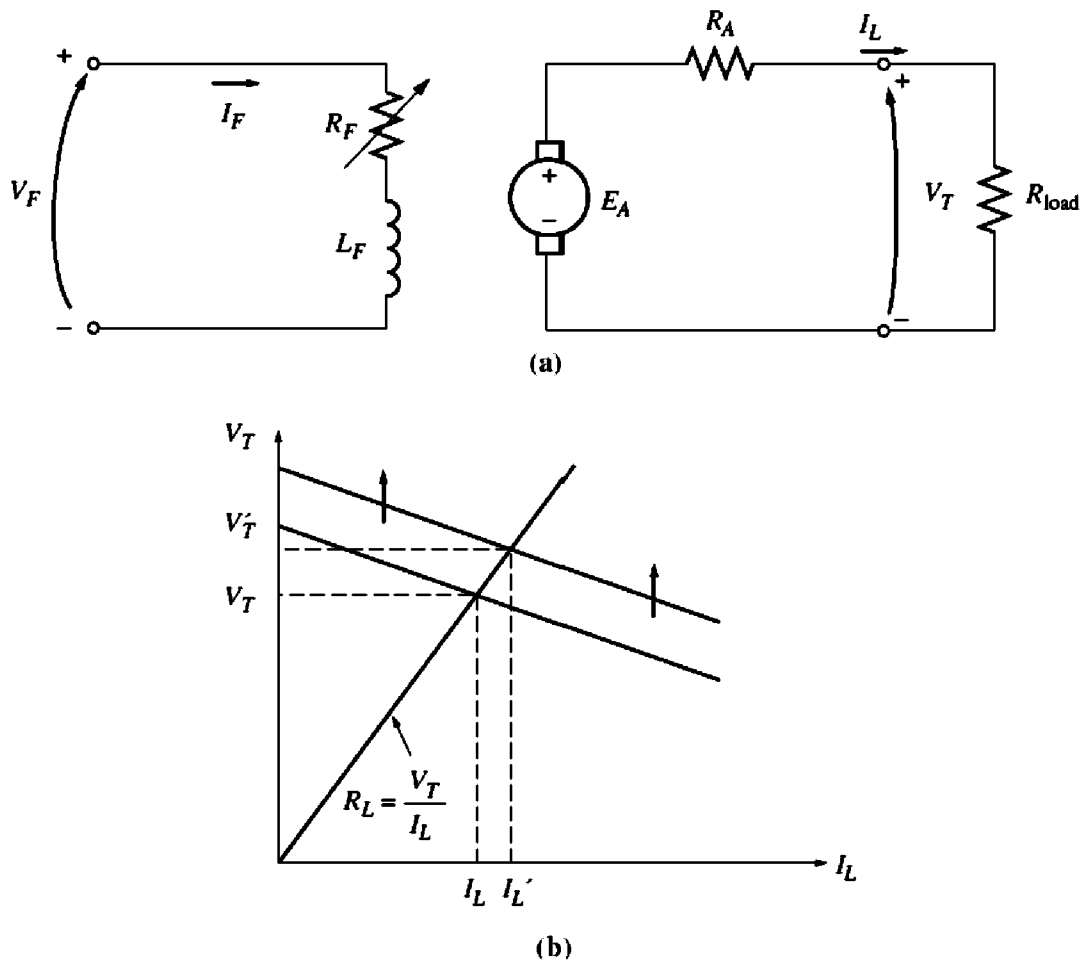
FIGURE 9-46

(a) A separately excited dc generator with a resistive load. (b) The effect of a decrease in field resistance on the output voltage of the generator.

$$\mathcal{F}_{\text{net}} = N_F I_F - \mathcal{F}_{\text{AR}} \quad (9-42)$$

As with dc motors, it is customary to define an *equivalent field current* that would produce the same output voltage as the combination of all the magnetomotive forces in the machine. The resulting voltage E_{A0} can then be determined by locating that equivalent field current on the magnetization curve. The equivalent field current of a separately excited dc generator is given by

$$I_F^* = I_F - \frac{\mathcal{F}_{\text{AR}}}{N_F} \quad (9-43)$$

Also, the difference between the speed of the magnetization curve and the real speed of the generator must be taken into account using Equation (9-13):

$$\frac{E_A}{E_{A0}} = \frac{n}{n_0} \quad (9-13)$$

The following example illustrates the analysis of a separately excited dc generator.

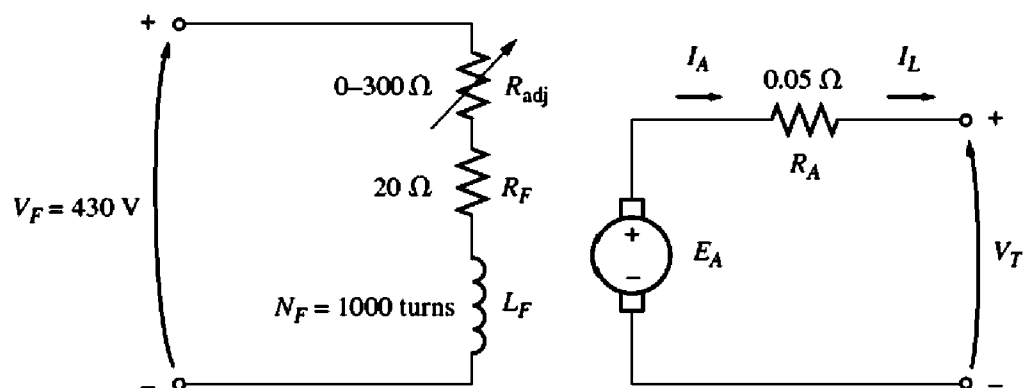

FIGURE 9-47
The separately excited dc generator in Example 9-9.

Example 9-9. A separately excited dc generator is rated at 172 kW, 430 V, 400 A, and 1800 r/min. It is shown in Figure 9-47, and its magnetization curve is shown in Figure 9-48. This machine has the following characteristics:

$$\begin{aligned} R_A &= 0.05 \, \Omega & V_F &= 430 \, \text{V} \\ R_F &= 20 \, \Omega & N_F &= 1000 \, \text{turns per pole} \\ R_{\text{adj}} &= 0 \text{ to } 300 \, \Omega \end{aligned}$$

- If the variable resistor R_{adj} in this generator's field circuit is adjusted to $63 \, \Omega$ and the generator's prime mover is driving it at 1600 r/min, what is this generator's no-load terminal voltage?
- What would its voltage be if a 360-A load were connected to its terminals? Assume that the generator has compensating windings.
- What would its voltage be if a 360-A load were connected to its terminals but the generator does not have compensating windings? Assume that its armature reaction at this load is $450 \, \text{A} \cdot \text{turns}$.
- What adjustment could be made to the generator to restore its terminal voltage to the value found in part *a*?
- How much field current would be needed to restore the terminal voltage to its no-load value? (Assume that the machine has compensating windings.) What is the required value for the resistor R_{adj} to accomplish this?

Solution

- If the generator's total field circuit resistance is

$$R_F + R_{\text{adj}} = 83 \, \Omega$$

then the field current in the machine is

$$I_F = \frac{V_F}{R_F} = \frac{430 \, \text{V}}{83 \, \Omega} = 5.2 \, \text{A}$$

From the machine's magnetization curve, this much current would produce a voltage $E_{A0} = 430 \, \text{V}$ at a speed of 1800 r/min. Since this generator is actually turning at $n_m = 1600 \, \text{r/min}$, its internal generated voltage E_A will be

$$\frac{E_A}{E_{A0}} = \frac{n}{n_0} \tag{9-13}$$

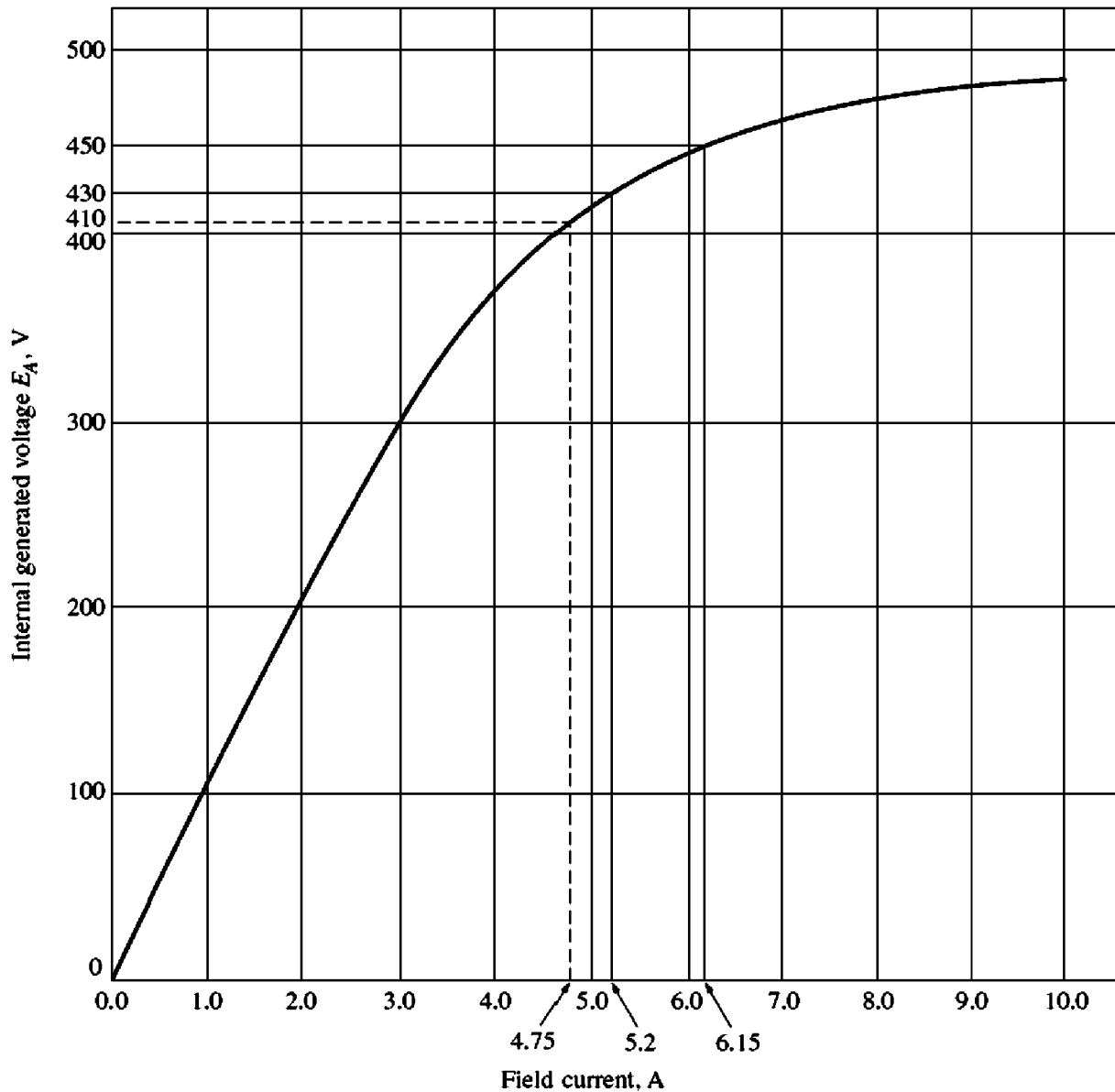

Note: When the field current is zero, E_A is about 3 V.

FIGURE 9-48

The magnetization curve for the generator in Example 9-9.

$$E_A = \frac{1600 \text{ r/min}}{1800 \text{ r/min}} 430 \text{ V} = 382 \text{ V}$$

Since $V_T = E_A$ at no-load conditions, the output voltage of the generator is $V_T = 382 \text{ V}$.

(b) If a 360-A load were connected to this generator's terminals, the terminal voltage of the generator would be

$$V_T = E_A - I_A R_A = 382 \text{ V} - (360 \text{ A})(0.05 \Omega) = 364 \text{ V}$$

(c) If a 360-A load were connected to this generator's terminals and the generator had 450 A • turns of armature reaction, the effective field current would be

$$I_F^* = I_F - \frac{\mathcal{F}_{AR}}{N_F} = 5.2 \text{ A} - \frac{450 \text{ A} \cdot \text{turns}}{1000 \text{ turns}} = 4.75 \text{ A}$$

From the magnetization curve, $E_{A0} = 410$ V, so the internal generated voltage at 1600 r/min would be

$$\frac{E_A}{E_{A0}} = \frac{n}{n_0} \quad (9-13)$$

$$E_A = \frac{1600 \text{ r/min}}{1800 \text{ r/min}} 410 \text{ V} = 364 \text{ V}$$

Therefore, the terminal voltage of the generator would be

$$V_T = E_A - I_A R_A = 364 \text{ V} - (360 \text{ A})(0.05 \Omega) = 346 \text{ V}$$

It is lower than before due to the armature reaction.

(d) The voltage at the terminals of the generator has fallen, so to restore it to its original value, the voltage of the generator must be increased. This requires an increase in E_A , which implies that R_{adj} must be decreased to increase the field current of the generator.

(e) For the terminal voltage to go back up to 382 V, the required value of E_A is

$$E_A = V_T + I_A R_A = 382 \text{ V} + (360 \text{ A})(0.05 \Omega) = 400 \text{ V}$$

To get a voltage E_A of 400 V at $n_m = 1600$ r/min, the equivalent voltage at 1800 r/min would be

$$\frac{E_A}{E_{A0}} = \frac{n}{n_0} \quad (9-13)$$

$$E_{A0} = \frac{1800 \text{ r/min}}{1600 \text{ r/min}} 400 \text{ V} = 450 \text{ V}$$

From the magnetization curve, this voltage would require a field current of $I_F = 6.15$ A. The field circuit resistance would have to be

$$\begin{aligned} R_F + R_{\text{adj}} &= \frac{V_F}{I_F} \\ 20 \Omega + R_{\text{adj}} &= \frac{430 \text{ V}}{6.15 \text{ A}} = 69.9 \Omega \\ R_{\text{adj}} &= 49.9 \Omega \approx 50 \Omega \end{aligned}$$

Notice that, for the same field current and load current, the generator with armature reaction had a lower output voltage than the generator without armature reaction. The armature reaction in this generator is exaggerated to illustrate its effects—it is a good deal smaller in well-designed modern machines.

9.13 THE SHUNT DC GENERATOR

A shunt dc generator is a dc generator that supplies its own field current by having its field connected directly across the terminals of the machine. The equivalent circuit of a shunt dc generator is shown in Figure 9-49. In this circuit, the armature current of the machine supplies both the field circuit and the load attached to the machine:

$$\boxed{I_A = I_F + I_L} \quad (9-44)$$

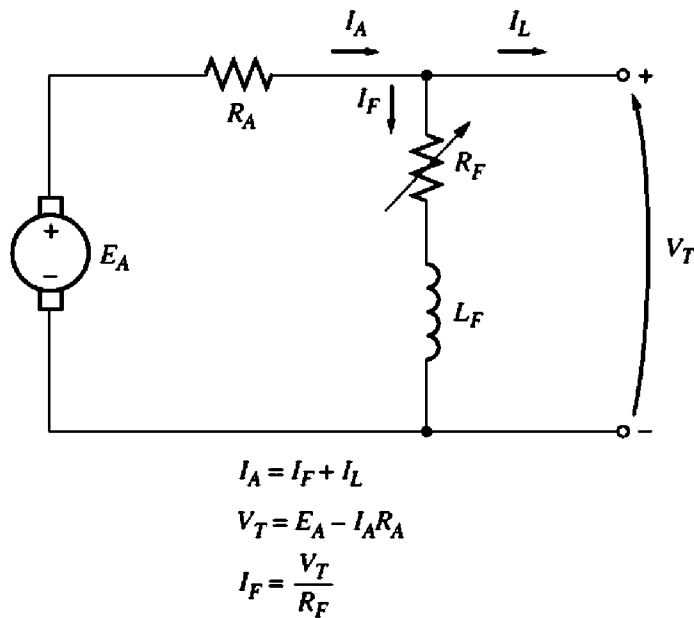

FIGURE 9-49
The equivalent circuit of a shunt dc generator.

The Kirchhoff's voltage law equation for the armature circuit of this machine is

$$V_T = E_A - I_A R_A \quad (9-45)$$

This type of generator has a distinct advantage over the separately excited dc generator in that no external power supply is required for the field circuit. But that leaves an important question unanswered: If the generator supplies its own field current, how does it get the initial field flux to start when it is first turned on?

Voltage Buildup in a Shunt Generator

Assume that the generator in Figure 9-49 has no load connected to it and that the prime mover starts to turn the shaft of the generator. How does an initial voltage appear at the terminals of the machine?

The voltage buildup in a dc generator depends on the presence of a *residual flux* in the poles of the generator. When a generator first starts to turn, an internal voltage will be generated which is given by

$$E_A = K\phi_{\text{res}}\omega$$

This voltage appears at the terminals of the generator (it may only be a volt or two). But when that voltage appears at the terminals, it causes a current to flow in the generator's field coil ($I_F = V_T \uparrow / R_F$). This field current produces a magnetomotive force in the poles, which increases the flux in them. The increase in flux causes an increase in $E_A = K\phi \uparrow \omega$, which increases the terminal voltage V_T . When V_T rises, I_F increases further, increasing the flux ϕ more, which increases E_A , etc.

This voltage buildup behavior is shown in Figure 9-50. Notice that it is the effect of magnetic saturation in the pole faces which eventually limits the terminal voltage of the generator.

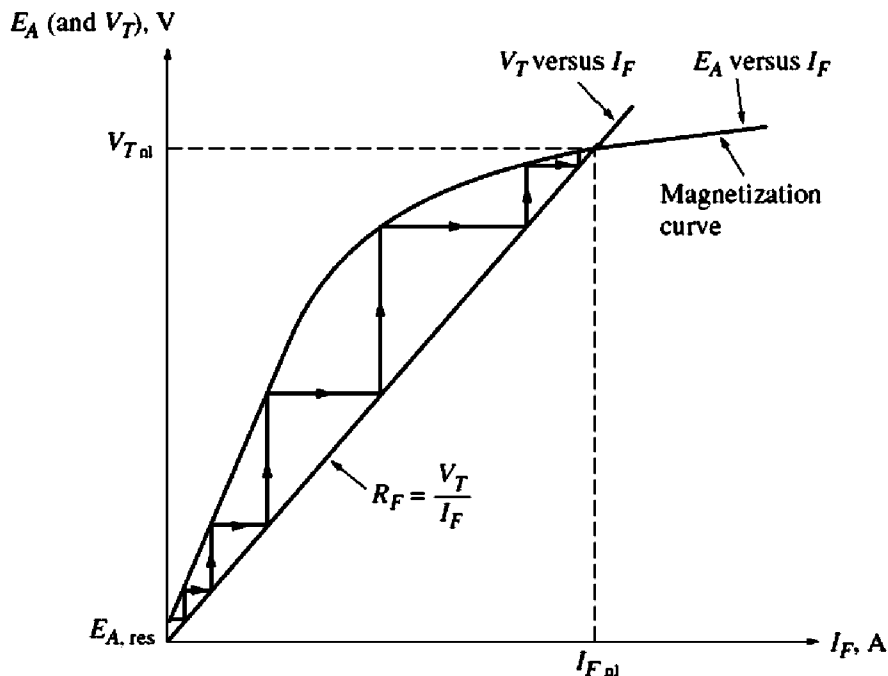

FIGURE 9-50
Voltage buildup on starting in a shunt dc generator.

Figure 9-50 shows the voltage buildup as though it occurred in discrete steps. These steps are drawn in to make obvious the positive feedback between the generator's internal voltage and its field current. In a real generator, the voltage does not build up in discrete steps: Instead both E_A and I_F increase simultaneously until steady-state conditions are reached.

What if a shunt generator is started and no voltage builds up? What could be wrong? There are several possible causes for the voltage to fail to build up during starting. Among them are

1. *There may be no residual magnetic flux* in the generator to start the process going. If the residual flux $\phi_{\text{res}} = 0$, then $E_A = 0$, and the voltage never builds up. If this problem occurs, disconnect the field from the armature circuit and connect it directly to an external dc source such as a battery. The current flow from this external dc source will leave a residual flux in the poles, which will then allow normal starting. This procedure is known as “flashing the field.”
2. *The direction of rotation of the generator may have been reversed*, or the connections of the field may have been reversed. In either case, the residual flux produces an internal generated voltage E_A . The voltage E_A produces a field current which produces a flux *opposing* the residual flux, instead of adding to it. Under these circumstances, the flux actually *decreases* below ϕ_{res} and no voltage can ever build up.

If this problem occurs, it can be fixed by reversing the direction of rotation, by reversing the field connections, or by flashing the field with the opposite magnetic polarity.

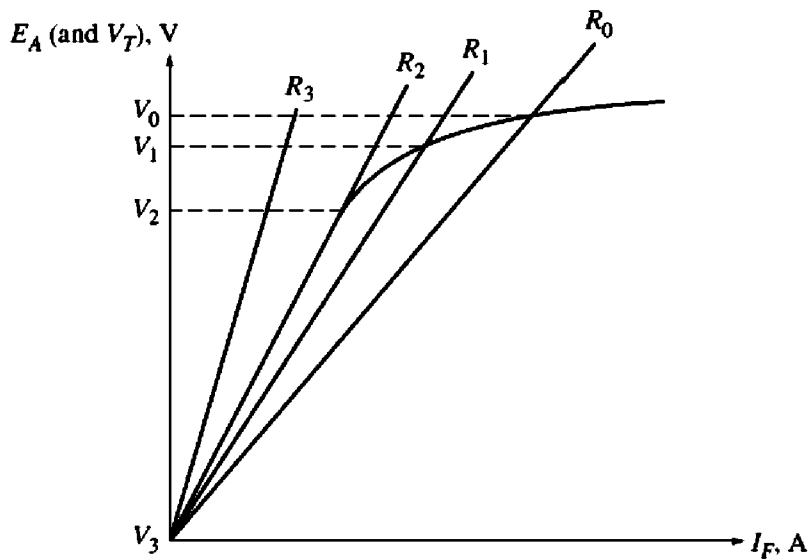

FIGURE 9-51

The effect of shunt field resistance on no-load terminal voltage in a dc generator. If $R_F > R_2$ (the critical resistance), then the generator's voltage will never build up.

3. *The field resistance may be adjusted to a value greater than the critical resistance.* To understand this problem, refer to Figure 9-51. Normally, the shunt generator will build up to the point where the magnetization curve intersects the field resistance line. If the field resistance has the value shown at R_2 in the figure, its line is nearly parallel to the magnetization curve. At that point, the voltage of the generator can fluctuate very widely with only tiny changes in R_F or I_A . This value of the resistance is called the *critical resistance*. If R_F exceeds the critical resistance (as at R_3 in the figure), then the steady-state operating voltage is essentially at the residual level, and it never builds up. The solution to this problem is to reduce R_F .

Since the voltage of the magnetization curve varies as a function of shaft speed, the critical resistance also varies with speed. In general, the lower the shaft speed, the lower the critical resistance.

The Terminal Characteristic of a Shunt DC Generator

The terminal characteristic of a shunt dc generator differs from that of a separately excited dc generator, because the amount of field current in the machine depends on its terminal voltage. To understand the terminal characteristic of a shunt generator, start with the machine unloaded and add loads, observing what happens.

As the load on the generator is increased, I_L increases and so $I_A = I_F + I_L \uparrow$ also increases. An increase in I_A increases the armature resistance voltage drop $I_A R_A$, causing $V_T = E_A - I_A \uparrow R_A$ to decrease. This is precisely the same behavior observed in a separately excited generator. However, when V_T decreases, the field current in the machine decreases with it. This causes the flux in the machine to

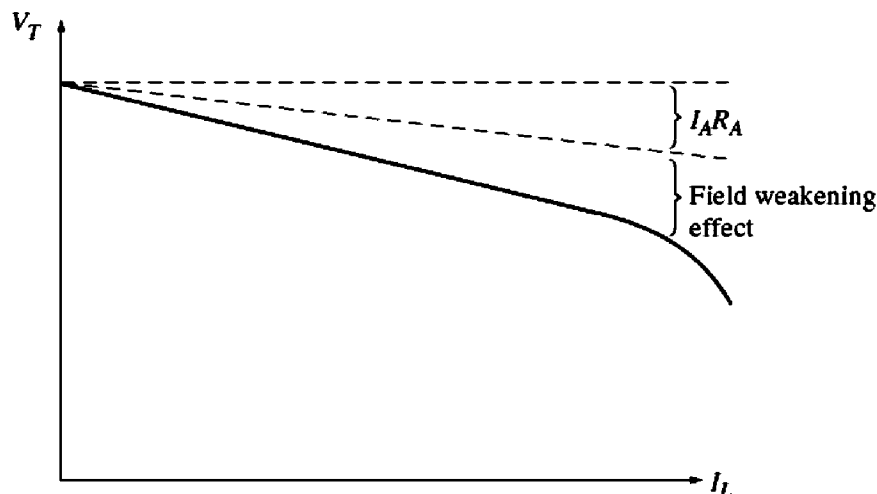

FIGURE 9-52
The terminal characteristic of a shunt dc generator.

decrease, decreasing E_A . Decreasing E_A causes a further decrease in the terminal voltage $V_T = E_A - I_A R_A$. The resulting terminal characteristic is shown in Figure 9-52. Notice that the voltage drop-off is steeper than just the $I_A R_A$ drop in a separately excited generator. In other words, the voltage regulation of this generator is worse than the voltage regulation of the same piece of equipment connected separately excited.

Voltage Control for a Shunt DC Generator

As with the separately excited generator, there are two ways to control the voltage of a shunt generator:

1. Change the shaft speed ω_m of the generator.
2. Change the field resistor of the generator, thus changing the field current.

Changing the field resistor is the principal method used to control terminal voltage in real shunt generators. If the field resistor R_F is decreased, then the field current $I_F = V_T / R_F$ increases. When I_F increases, the machine's flux ϕ increases, causing the internal generated voltage E_A to increase. The increase in E_A causes the terminal voltage of the generator to increase as well.

The Analysis of Shunt DC Generators

The analysis of a shunt dc generator is somewhat more complicated than the analysis of a separately excited generator, because the field current in the machine depends directly on the machine's own output voltage. First the analysis of shunt generators is studied for machines with no armature reaction, and afterward the effects are armature reaction are included.

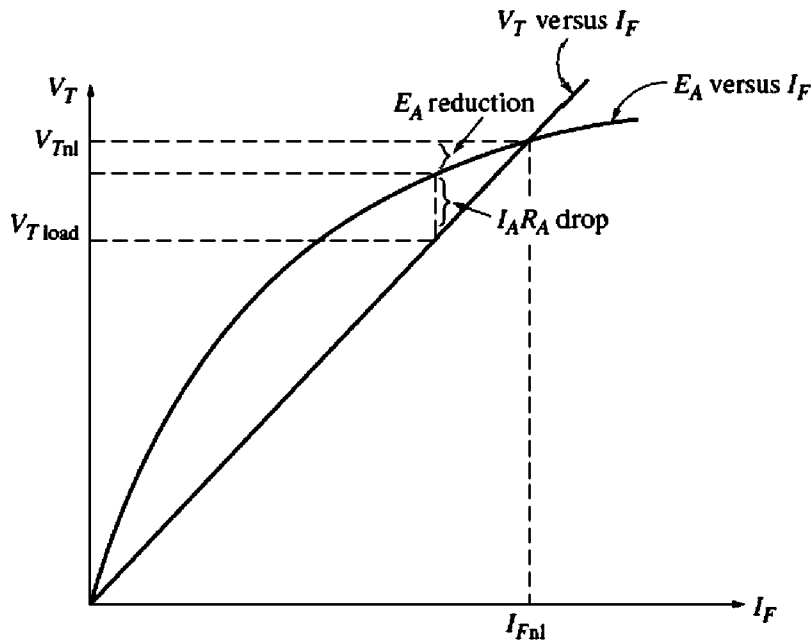

FIGURE 9-53

Graphical analysis of a shunt dc generator with compensating windings.

Figure 9-53 shows a magnetization curve for a shunt dc generator drawn at the actual operating speed of the machine. The field resistance R_F , which is just equal to V_T/I_F , is shown by a straight line laid over the magnetization curve. *At no load*, $V_T = E_A$ and the generator operates at the voltage where the magnetization curve intersects the field resistance line.

The key to understanding the graphical analysis of shunt generators is to remember Kirchhoff's voltage law (KVL):

$$V_T = E_A - I_A R_A \quad (9-45)$$

or

$$\boxed{E_A - V_T = I_A R_A} \quad (9-46)$$

The difference between the internal generated voltage and the terminal voltage is just the $I_A R_A$ drop in the machine. The line of all possible values of E_A is the magnetization curve, and the line of all possible terminal voltages is the resistor line ($I_F = V_T/R_F$). Therefore, to find the terminal voltage for a given load, just determine the $I_A R_A$ drop and locate the place on the graph where that drop fits *exactly* between the E_A line and the V_T line. There are at most two places on the curve where the $I_A R_A$ drop will fit exactly. If there are two possible positions, the one nearer the no-load voltage will represent a normal operating point.

A detailed plot showing several different points on a shunt generator's characteristic is shown in Figure 9-54. Note the dashed line in Figure 9-54b. This line is the terminal characteristic when the load is being reduced. The reason that it does not coincide with the line of increasing load is the hysteresis in the stator poles of the generator.

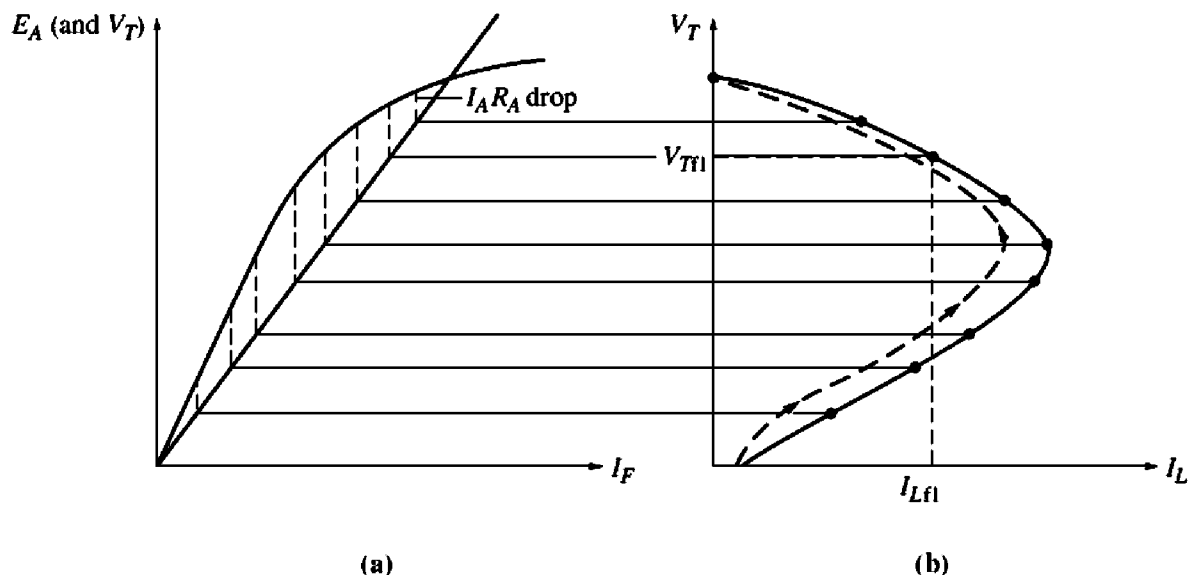

FIGURE 9-54
Graphical derivation of the terminal characteristic of a shunt dc generator.

If armature reaction is present in a shunt generator, this process becomes a little more complicated. The armature reaction produces a demagnetizing magnetomotive force in the generator at the same time that the $I_A R_A$ drop occurs in the machine.

To analyze a generator with armature reaction present, assume that its armature current is known. Then the resistive voltage drop $I_A R_A$ is known, and the demagnetizing magnetomotive force of the armature current is known. The terminal voltage of this generator must be large enough to supply the generator's flux *after the demagnetizing effects of armature reaction have been subtracted*. To meet this requirement both the armature reaction magnetomotive force and the $I_A R_A$ drop must fit between the E_A line and the V_T line. To determine the output voltage for a given magnetomotive force, simply locate the place under the magnetization curve where the triangle formed by the armature reaction and $I_A R_A$ effects *exactly fits* between the line of possible V_T values and the line of possible E_A values (see Figure 9-55).

9.14 THE SERIES DC GENERATOR

A series dc generator is a generator whose field is connected in series with its armature. Since the armature has a *much* higher current than a shunt field, the series field in a generator of this sort will have only a very few turns of wire, and the wire used will be much thicker than the wire in a shunt field. Because magnetomotive force is given by the equation $\mathcal{F} = NI$, exactly the same magnetomotive force can be produced from a few turns with high current as can be produced from many turns with low current. Since the full-load current flows through it, a series field is designed to have the lowest possible resistance. The equivalent circuit of a series dc generator is shown in Figure 9-56. Here, the armature current, field

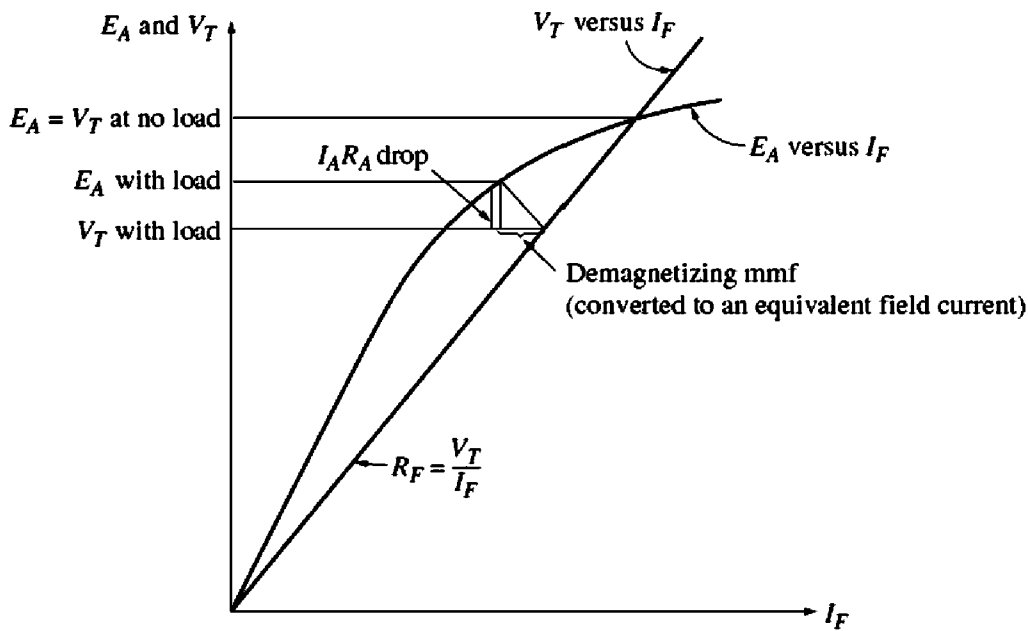

FIGURE 9-55
Graphical analysis of a shunt dc generator with armature reaction.

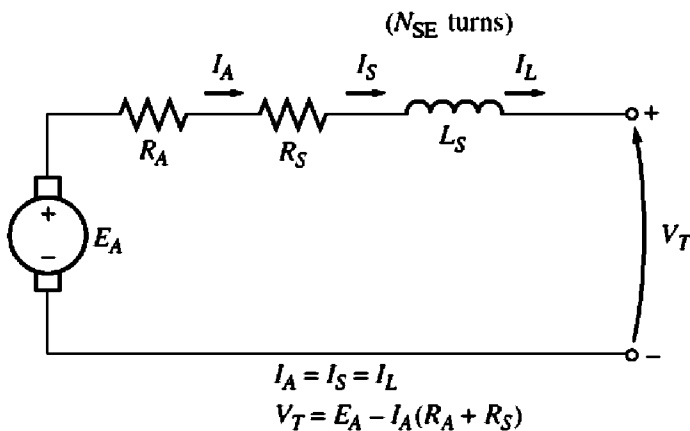

FIGURE 9-56
The equivalent circuit of a series dc generator.

current, and line current all have the same value. The Kirchhoff's voltage law equation for this machine is

$$V_T = E_A - I_A(R_A + R_S) \quad (9-47)$$

The Terminal Characteristic of a Series Generator

The magnetization curve of a series dc generator looks very much like the magnetization curve of any other generator. At no load, however, there is no field current, so V_T is reduced to a small level given by the residual flux in the machine. As the load increases, the field current rises, so E_A rises rapidly. The $I_A(R_A + R_S)$ drop goes up too, but at first the increase in E_A goes up more rapidly than the $I_A(R_A + R_S)$ drop rises, so V_T increases. After a while, the machine approaches saturation, and E_A

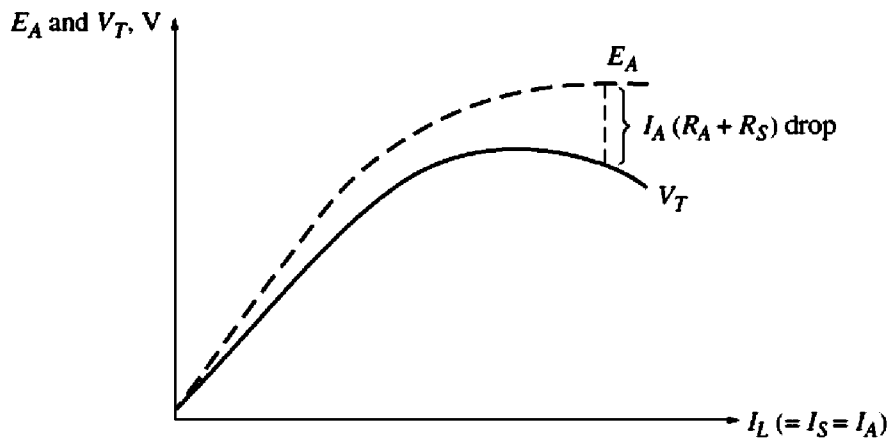

FIGURE 9-57
Derivation of the terminal characteristic for a series dc generator.

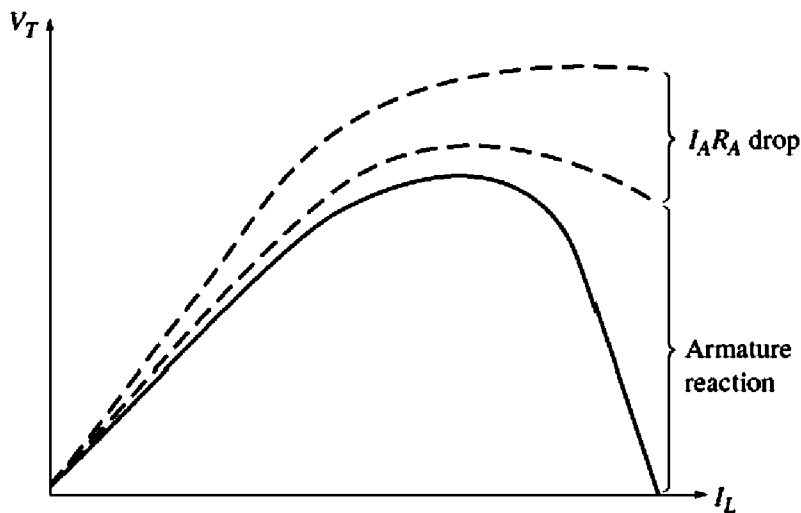
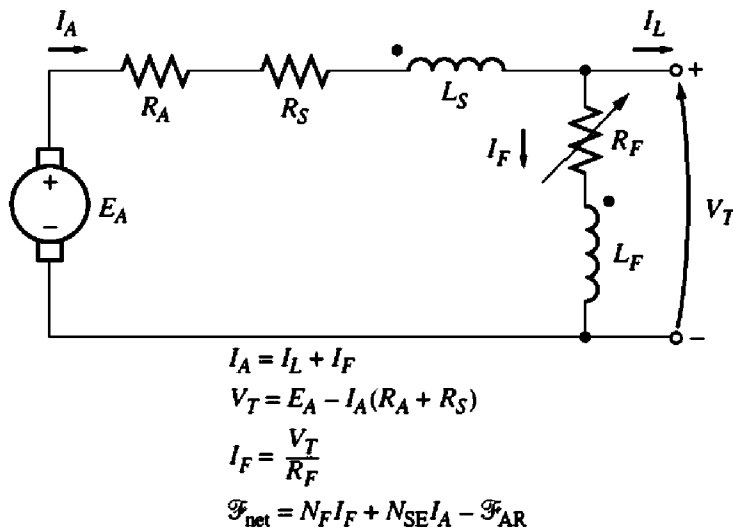

FIGURE 9-58
A series generator terminal characteristic with large armature reaction effects, suitable for electric welders.

becomes almost constant. At that point, the resistive drop is the predominant effect, and V_T starts to fall.

This type of characteristic is shown in Figure 9-57. It is obvious that this machine would make a bad constant-voltage source. In fact, its voltage regulation is a large negative number.

Series generators are used only in a few specialized applications, where the steep voltage characteristic of the device can be exploited. One such application is arc welding. Series generators used in arc welding are deliberately designed to have a large armature reaction, which gives them a terminal characteristic like the one shown in Figure 9-58. Notice that when the welding electrodes make contact with each other before welding commences, a very large current flows. As the operator separates the welding electrodes, there is a very steep rise in the generator's voltage, while the current remains high. This voltage ensures that a welding arc is maintained through the air between the electrodes.

FIGURE 9-59

The equivalent circuit of a cumulatively compounded dc generator with a long-shunt connection.

9.15 THE CUMULATIVELY COMPOUNDED DC GENERATOR

A cumulatively compounded dc generator is a dc generator with *both series and shunt fields*, connected so that the magnetomotive forces from the two fields are additive. Figure 9-59 shows the equivalent circuit of a cumulatively compounded dc generator in the “long-shunt” connection. The dots that appear on the two field coils have the same meaning as the dots on a transformer: *Current flowing into a dot produces a positive magnetomotive force*. Notice that the armature current flows into the dotted end of the series field coil and that the shunt current I_F flows into the dotted end of the shunt field coil. Therefore, the total magnetomotive force on this machine is given by

$$\mathcal{F}_{net} = \mathcal{F}_F + \mathcal{F}_{SE} - \mathcal{F}_{AR} \quad (9-48)$$

where \mathcal{F}_F is the shunt field magnetomotive force, \mathcal{F}_{SE} is the series field magnetomotive force, and \mathcal{F}_{AR} is the armature reaction magnetomotive force. The equivalent effective shunt field current for this machine is given by

$$N_F I_F^* = N_F I_F + N_{SE} I_A - \mathcal{F}_{AR}$$

$$I_F^* = I_F + \frac{N_{SE}}{N_F} I_A - \frac{\mathcal{F}_{AR}}{N_F} \quad (9-49)$$

The other voltage and current relationships for this generator are

$$I_A = I_F + I_L \quad (9-50)$$

$$V_T = E_A - I_A(R_A + R_S) \quad (9-51)$$

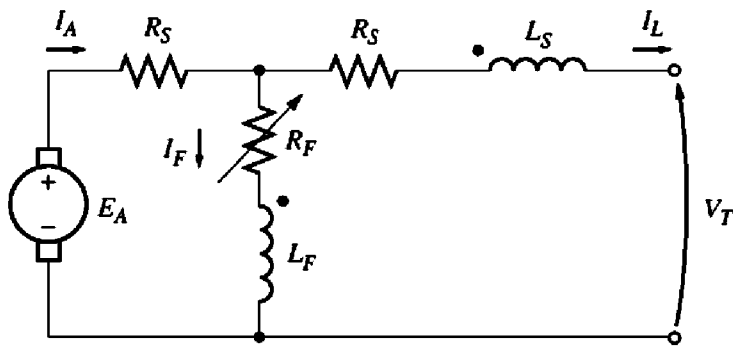

FIGURE 9-60

The equivalent circuit of a cumulatively compounded dc generator with a short-shunt connection.

$$I_F = \frac{V_T}{R_F} \quad (9-52)$$

There is another way to hook up a cumulatively compounded generator. It is the “short-shunt” connection, where the series field is outside the shunt field circuit and has current I_L flowing through it instead of I_A . A short-shunt cumulatively compounded dc generator is shown in Figure 9-60.

The Terminal Characteristic of a Cumulatively Compounded DC Generator

To understand the terminal characteristic of a cumulatively compounded dc generator, it is necessary to understand the competing effects that occur within the machine.

Suppose that the load on the generator is increased. Then as the load increases, the load current I_L increases. Since $I_A = I_F + I_L \uparrow$, the armature current I_A increases too. At this point two effects occur in the generator:

1. As I_A increases, the $I_A(R_A + R_S)$ voltage drop increases as well. This tends to cause a decrease in the terminal voltage $V_T = E_A - I_A \uparrow (R_A + R_S)$.
2. As I_A increases, the series field magnetomotive force $\mathcal{F}_{SE} = N_{SE} I_A$ increases too. This increases the total magnetomotive force $\mathcal{F}_{tot} = N_F I_F + N_{SE} I_A \uparrow$ which increases the flux in the generator. The increased flux in the generator increases E_A , which in turn tends to make $V_T = E_A \uparrow - I_A(R_A + R_S)$ rise.

These two effects oppose each other, with one tending to *increase* V_T and the other tending to *decrease* V_T . Which effect predominates in a given machine? It all depends on just how many series turns were placed on the poles of the machine. The question can be answered by taking several individual cases:

1. *Few series turns (N_{SE} small).* If there are only a few series turns, the resistive voltage drop effect wins hands down. The voltage falls off just as in a shunt

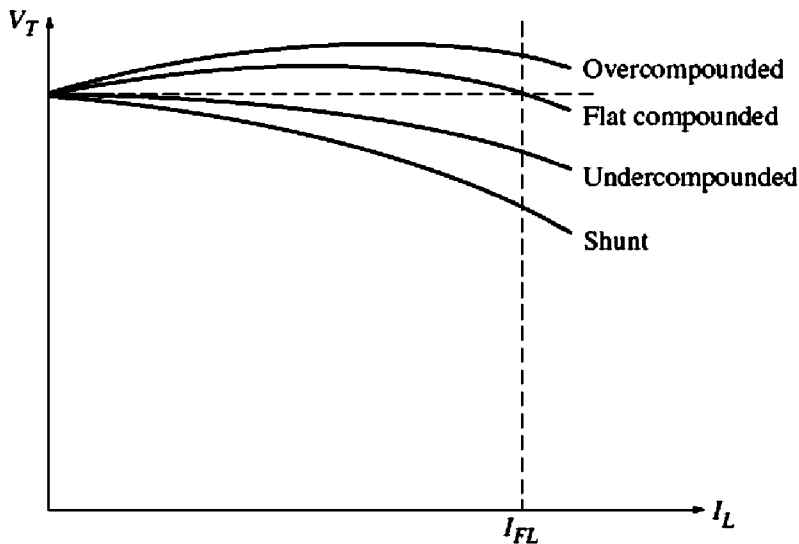

FIGURE 9-61

Terminal characteristics of cumulatively compounded dc generators.

generator, but not quite as steeply (Figure 9-61). This type of construction, where the full-load terminal voltage is less than the no-load terminal voltage, is called *undercompounded*.

2. *More series turns (N_{SE} larger)*. If there are a few more series turns of wire on the poles, then at first the flux-strengthening effect wins, and the terminal voltage rises with the load. However, as the load continues to increase, magnetic saturation sets in, and the resistive drop becomes stronger than the flux increase effect. In such a machine, *the terminal voltage first rises and then falls as the load increases*. If V_T at no load is equal to V_T at full load, the generator is called *flat-compounded*.
3. *Even more series turns are added (N_{SE} large)*. If even more series turns are added to the generator, the flux-strengthening effect predominates for a longer time before the resistive drop takes over. The result is a characteristic with the full-load terminal voltage actually higher than the no-load terminal voltage. If V_T at a full load exceeds V_T at no load, the generator is called *overcompounded*.

All these possibilities are illustrated in Figure 9-61.

It is also possible to realize all these voltage characteristics in a *single generator* if a diverter resistor is used. Figure 9-62 shows a cumulatively compounded dc generator with a relatively large number of series turns N_{SE} . A diverter resistor is connected around the series field. If the resistor R_{div} is adjusted to a large value, most of the armature current flows through the series field coil, and the generator is overcompounded. On the other hand, if the resistor R_{div} is adjusted to a small value, most of the current flows around the series field through R_{div} , and the generator is undercompounded. It can be smoothly adjusted with the resistor to have any desired amount of compounding.

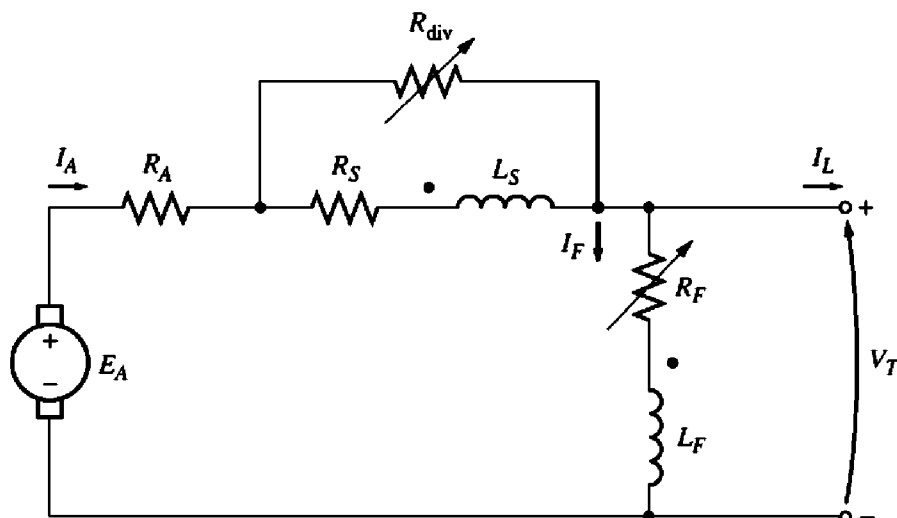

FIGURE 9-62

A cumulatively compounded dc generator with a series diverter resistor.

Voltage Control of Cumulatively Compounded DC Generators

The techniques available for controlling the terminal voltage of a cumulatively compounded dc generator are exactly the same as the techniques for controlling the voltage of a shunt dc generator:

1. Change the speed of rotation. An increase in ω causes $E_A = K\phi\omega \uparrow$ to increase, increasing the terminal voltage $V_T = E_A \uparrow - I_A(R_A + R_S)$.
2. Change the field current. A decrease in R_F causes $I_F = V_T/R_F \downarrow$ to increase, which increases the total magnetomotive force in the generator. As \mathcal{F}_{tot} increases, the flux ϕ in the machine increases, and $E_A = K\phi\omega$ increases. Finally, an increase in E_A raises V_T .

Analysis of Cumulatively Compounded DC Generators

Equations (9-53) and (9-54) are the key to describing the terminal characteristics of a cumulatively compounded dc generator. The equivalent shunt field current I_{eq} due to the effects of the series field and armature reaction is given by

$$I_{\text{eq}} = \frac{N_{SE}}{N_F} I_A - \frac{\mathcal{F}_{AR}}{N_F} \quad (9-53)$$

Therefore, the total effective shunt field current in the machine is

$$I_F^* = I_F + I_{\text{eq}} \quad (9-54)$$

This equivalent current I_{eq} represents a horizontal distance to the left or the right of the field resistance line ($R_F = V_T/R_F$) along the axes of the magnetization curve.

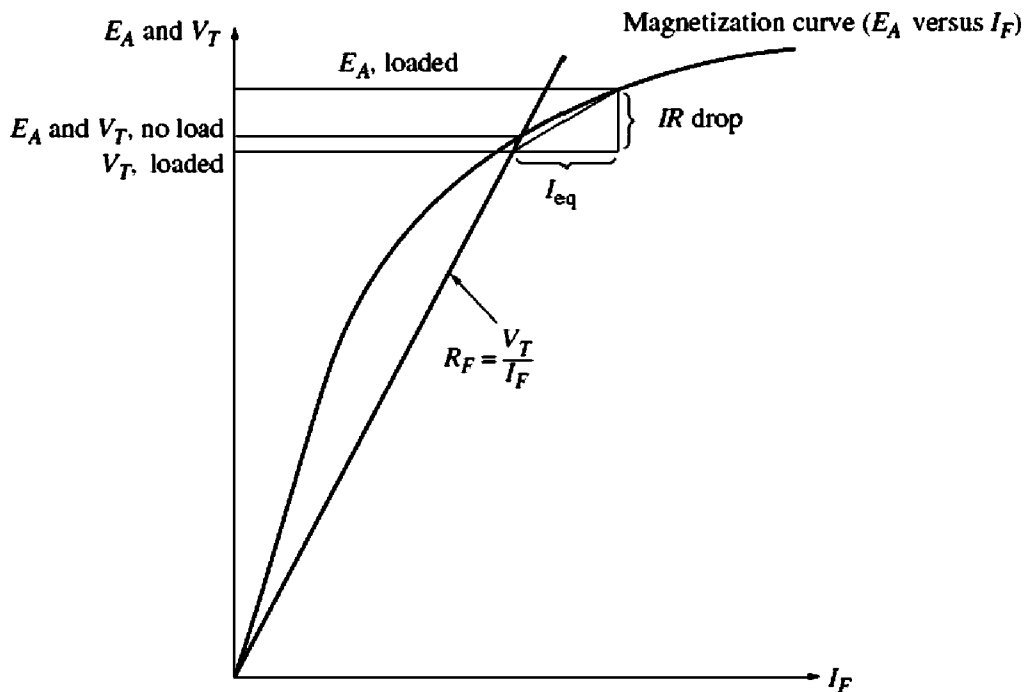

FIGURE 9-63
Graphical analysis of a cumulatively compounded dc generator.

The resistive drop in the generator is given by $I_A(R_A + R_S)$, which is a length along the vertical axis on the magnetization curve. Both the equivalent current I_{eq} and the resistive voltage drop $I_A(R_A + R_S)$ depend on the strength of the armature current I_A . Therefore, they form the two sides of a triangle whose magnitude is a function of I_A . To find the output voltage for a given load, determine the size of the triangle and find the one point where it *exactly* fits between the field current line and the magnetization curve.

This idea is illustrated in Figure 9-63. The terminal voltage at no-load conditions will be the point at which the resistor line and the magnetization curve intersect, as before. As load is added to the generator, the series field magnetomotive force increases, increasing the equivalent shunt field current I_{eq} and the resistive voltage drop $I_A(R_A + R_S)$ in the machine. To find the new output voltage in this generator, slide the leftmost edge of the resulting triangle along the shunt field current line until the upper tip of the triangle touches the magnetization curve. The upper tip of the triangle then represents the internal generated voltage in the machine, while the lower line represents the terminal voltage of the machine.

Figure 9-64 shows this process repeated several times to construct a complete terminal characteristic for the generator.

9.16 THE DIFFERENTIALLY COMPOUNDED DC GENERATOR

A differentially compounded dc generator is a generator with both shunt and series fields, but this time *their magnetomotive forces subtract from each other*. The

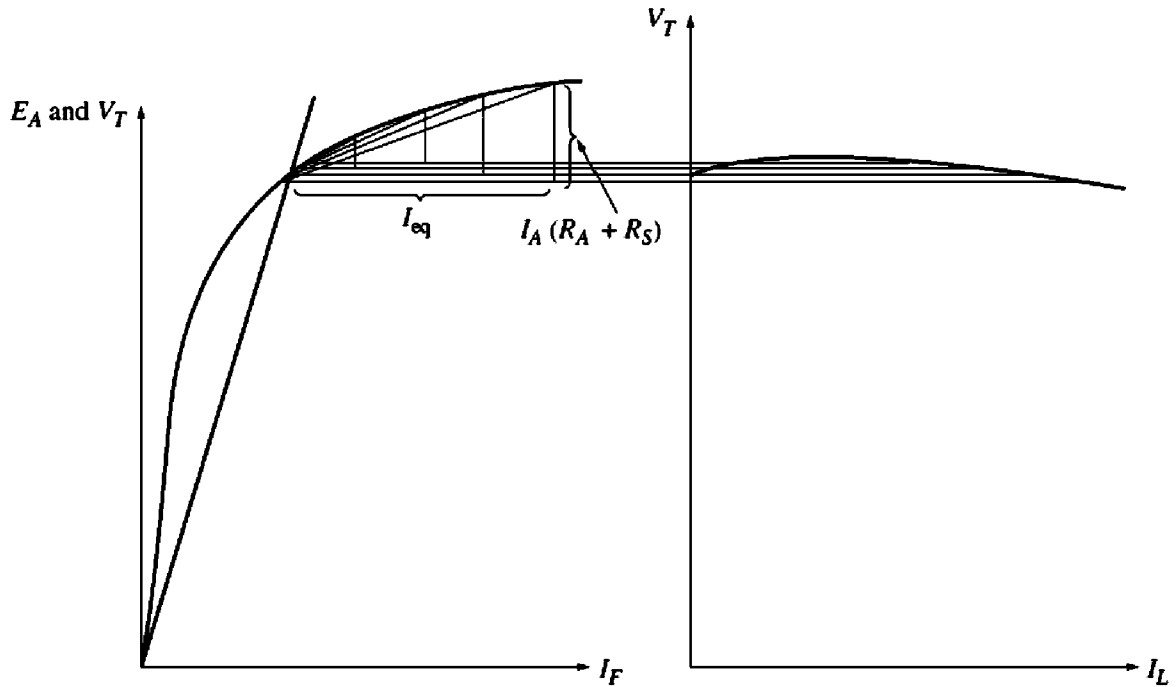

FIGURE 9-64
Graphical derivation of the terminal characteristic of a cumulatively compounded dc generator.

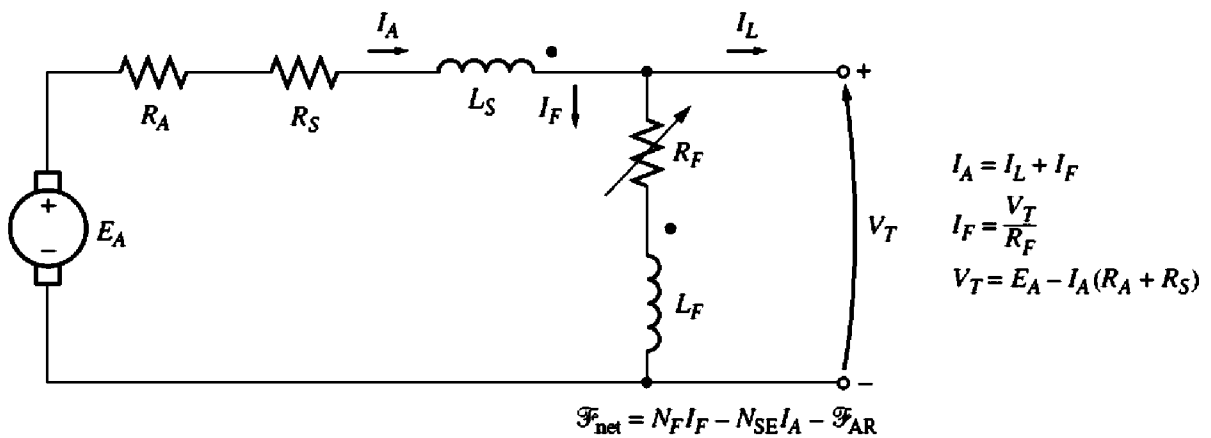

FIGURE 9-65
The equivalent circuit of a differentially compounded dc generator with a long-shunt connection.

equivalent circuit of a differentially compounded dc generator is shown in Figure 9-65. Notice that the armature current is now flowing *out of a dotted coil end*, while the shunt field current is flowing *into a dotted coil end*. In this machine, the net magnetomotive force is

$$\mathcal{F}_{\text{net}} = \mathcal{F}_F - \mathcal{F}_{SE} - \mathcal{F}_{AR} \tag{9-55}$$

$$\mathcal{F}_{\text{net}} = N_F I_F - N_{SE} I_A - \mathcal{F}_{AR} \tag{9-56}$$

and the equivalent shunt field current due to the series field and armature reaction is given by

$$I_{\text{eq}} = -\frac{N_{\text{SE}}}{N_{\text{F}}} I_{\text{A}} - \frac{\mathcal{F}_{\text{AR}}}{N_{\text{F}}} \quad (9-57)$$

The total effective shunt field current in this machine is

$$I_{\text{F}}^* = I_{\text{F}} + I_{\text{eq}} \quad (9-58a)$$

or

$$I_{\text{F}}^* = I_{\text{F}} - \frac{N_{\text{SE}}}{N_{\text{F}}} I_{\text{A}} - \frac{\mathcal{F}_{\text{AR}}}{N_{\text{F}}} \quad (9-58b)$$

Like the cumulatively compounded generator, the differentially compounded generator can be connected in either long-shunt or short-shunt fashion.

The Terminal Characteristic of a Differentially Compounded DC Generator

In the differentially compounded dc generator, the same two effects occur that were present in the cumulatively compounded dc generator. This time, though, the effects both act in the same direction. They are

1. As I_{A} increases, the $I_{\text{A}}(R_{\text{A}} + R_{\text{S}})$ voltage drop increases as well. This increase tends to cause the terminal voltage to decrease $V_{\text{T}} = E_{\text{A}} - I_{\text{A}}(R_{\text{A}} + R_{\text{S}})$.
2. As I_{A} increases, the series field magnetomotive force $\mathcal{F}_{\text{SE}} = N_{\text{SE}} I_{\text{A}}$ increases too. This increase in series field magnetomotive force *reduces* the net magnetomotive force on the generator ($\mathcal{F}_{\text{tot}} = N_{\text{F}} I_{\text{F}} - N_{\text{SE}} I_{\text{A}}$), which in turn reduces the net flux in the generator. A decrease in flux decreases E_{A} , which in turn decreases V_{T} .

Since both these effects tend to *decrease* V_{T} , the voltage drops drastically as the load is increased on the generator. A typical terminal characteristic for a differentially compounded dc generator is shown in Figure 9-66.

Voltage Control of Differentially Compounded DC Generators

Even though the voltage drop characteristics of a differentially compounded dc generator are quite bad, it is still possible to adjust the terminal voltage at any given load setting. The techniques available for adjusting terminal voltage are exactly the same as those for shunt and cumulatively compounded dc generators:

1. Change the speed of rotation ω_{m} .
2. Change the field current I_{F} .

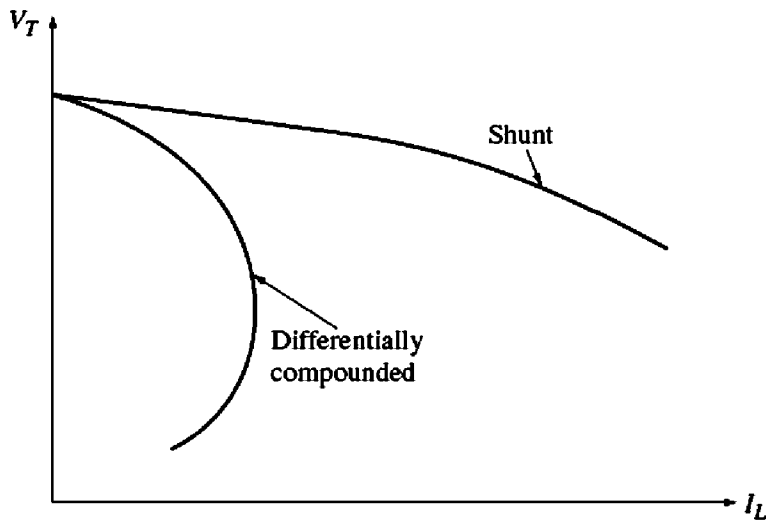

FIGURE 9-66
The terminal characteristic of a differentially compounded dc generator.

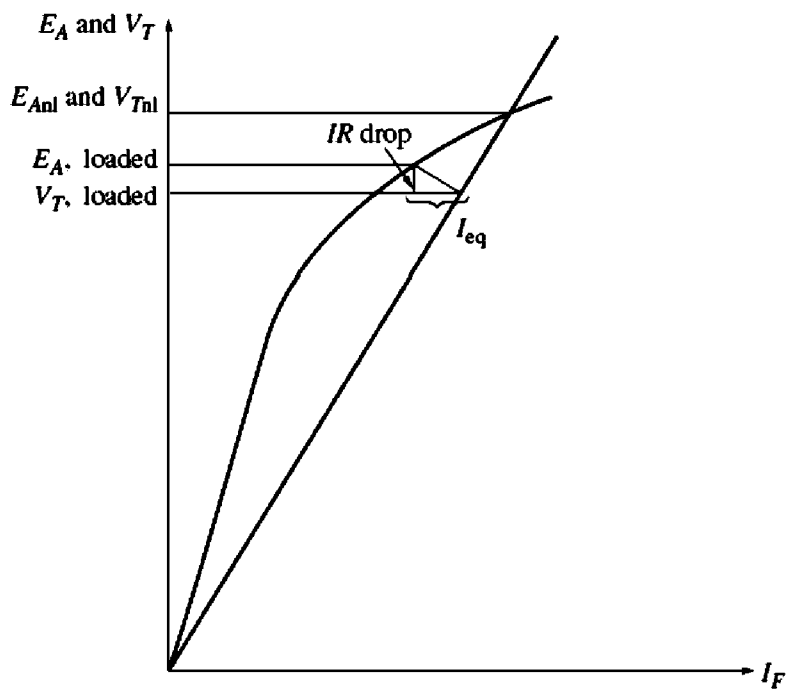

FIGURE 9-67
Graphical analysis of a differentially compounded dc generator.

Graphical Analysis of a Differentially Compounded DC Generator

The voltage characteristic of a differentially compounded dc generator is graphically determined in precisely the same manner as that used for the cumulatively compounded dc generator. To find the terminal characteristic of the machine, refer to Figure 9-67.

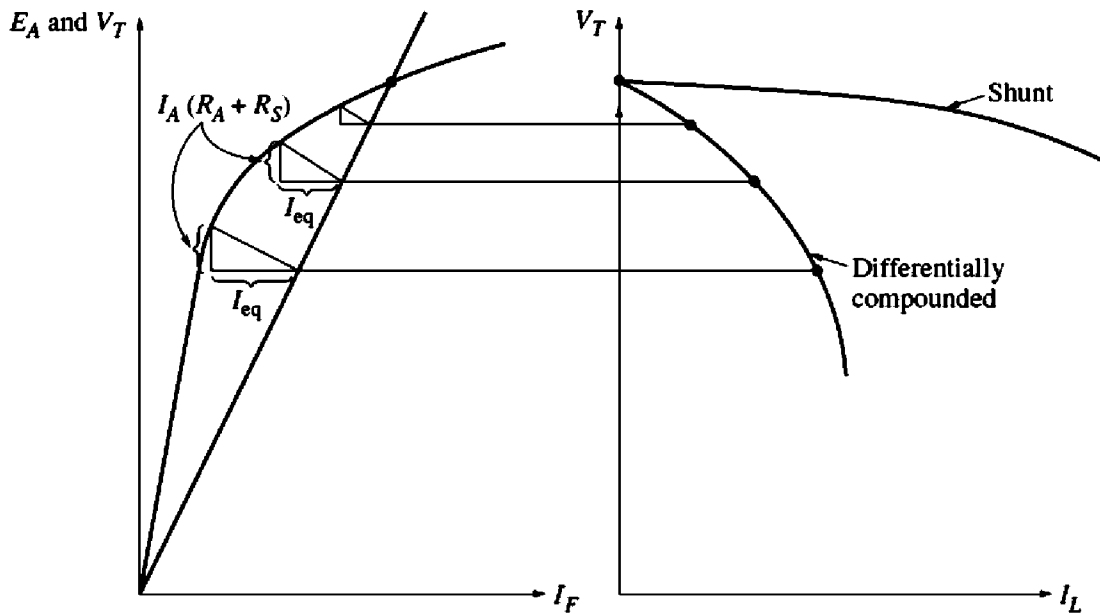

FIGURE 9-68

Graphical derivation of the terminal characteristic of a differentially compounded dc generator.

The portion of the effective shunt field current due to the actual shunt field is always equal to V_T/R_F , since that much current is present in the shunt field. The remainder of the effective field current is given by I_{eq} and is the sum of the series field and armature reaction effects. This equivalent current I_{eq} represents a *negative* horizontal distance along the axes of the magnetization curve, since both the series field and the armature reaction are subtractive.

The resistive drop in the generator is given by $I_A(R_A + R_S)$, which is a length along the vertical axis on the magnetization curve. To find the output voltage for a given load, determine the size of the triangle formed by the resistive voltage drop and I_{eq} , and find the one point where it *exactly* fits between the field current line and the magnetization curve.

Figure 9-68 shows this process repeated several times to construct a complete terminal characteristic for the generator.

9.17 SUMMARY

There are several types of dc motors, differing in the manner in which their field fluxes are derived. These types of motors are separately excited, shunt, permanent-magnet, series, and compounded. The manner in which the flux is derived affects the way it varies with the load, which in turn affects the motor's overall torque–speed characteristic.

A shunt or separately excited dc motor has a torque–speed characteristic whose speed drops linearly with increasing torque. Its speed can be controlled by changing its field current, its armature voltage, or its armature resistance.

A permanent-magnet dc motor is the same basic machine except that its flux is derived from permanent magnets. Its speed can be controlled by any of the above methods except varying the field current.

A series motor has the highest starting torque of any dc motor but tends to overspeed at no load. It is used for very high-torque applications where speed regulation is not important, such as a car starter.

A cumulatively compounded dc motor is a compromise between the series and the shunt motor, having some of the best characteristics of each. On the other hand, a differentially compounded dc motor is a complete disaster. It is unstable and tends to overspeed as load is added to it.

DC generators are dc machines used as generators. There are several different types of dc generators, differing in the manner in which their field fluxes are derived. These methods affect the output characteristics of the different types of generators. The common dc generator types are separately excited, shunt, series, cumulatively compounded, and differentially compounded.

The shunt and compounded dc generators depend on the nonlinearity of their magnetization curves for stable output voltages. If the magnetization curve of a dc machine were a straight line, then the magnetization curve and the terminal voltage line of the generator would never intersect. There would thus be no stable no-load voltage for the generator. Since nonlinear effects are at the heart of the generator's operation, the output voltages of dc generators can only be determined graphically or numerically by using a computer.

Today, dc generators have been replaced in many applications by ac power sources and solid-state electronic components. This is true even in the automobile, which is one of the most common users of dc power.

QUESTIONS

- 9-1. What is the speed regulation of a dc motor?
- 9-2. How can the speed of a shunt dc motor be controlled? Explain in detail.
- 9-3. What is the practical difference between a separately excited and a shunt dc motor?
- 9-4. What effect does armature reaction have on the torque-speed characteristic of a shunt dc motor? Can the effects of armature reaction be serious? What can be done to remedy this problem?
- 9-5. What are the desirable characteristics of the permanent magnets in PMDC machines?
- 9-6. What are the principal characteristics of a series dc motor? What are its uses?
- 9-7. What are the characteristics of a cumulatively compounded dc motor?
- 9-8. What are the problems associated with a differentially compounded dc motor?
- 9-9. What happens in a shunt dc motor if its field circuit opens while it is running?
- 9-10. Why is a starting resistor used in dc motor circuits?
- 9-11. How can a dc starting resistor be cut out of a motor's armature circuit at just the right time during starting?
- 9-12. What is the Ward-Leonard motor control system? What are its advantages and disadvantages?
- 9-13. What is regeneration?
- 9-14. What are the advantages and disadvantages of solid-state motor drives compared to the Ward-Leonard system?

- 9-15. What is the purpose of a field loss relay?
- 9-16. What types of protective features are included in typical solid-state dc motor drives? How do they work?
- 9-17. How can the direction of rotation of a separately excited dc motor be reversed?
- 9-18. How can the direction of rotation of a shunt dc motor be reversed?
- 9-19. How can the direction of rotation of a series dc motor be reversed?
- 9-20. Name and describe the features of the five types of generators covered in this chapter.
- 9-21. How does the voltage buildup occur in a shunt dc generator during starting?
- 9-22. What could cause voltage buildup on starting to fail to occur? How can this problem be remedied?
- 9-23. How does armature reaction affect the output voltage in a separately excited dc generator?
- 9-24. What causes the extraordinarily fast voltage drop with increasing load in a differentially compounded dc generator?

PROBLEMS

Problems 9-1 to 9-12 refer to the following dc motor:

$P_{\text{rated}} = 15 \text{ hp}$	$I_{L,\text{rated}} = 55 \text{ A}$
$V_T = 240 \text{ V}$	$N_F = 2700 \text{ turns per pole}$
$n_{\text{rated}} = 1200 \text{ r/min}$	$N_{SE} = 27 \text{ turns per pole}$
$R_A = 0.40 \ \Omega$	$R_F = 100 \ \Omega$
$R_S = 0.04 \ \Omega$	$R_{\text{adj}} = 100 \text{ to } 400 \ \Omega$

Rotational losses are 1800 W at full load. Magnetization curve is as shown in Figure P9-1.

In Problems 9-1 through 9-7, assume that the motor described above can be connected in shunt. The equivalent circuit of the shunt motor is shown in Figure P9-2.

- 9-1. If the resistor R_{adj} is adjusted to 175 Ω what is the rotational speed of the motor at no-load conditions?
- 9-2. Assuming no armature reaction, what is the speed of the motor at full load? What is the speed regulation of the motor?
- 9-3. If the motor is operating at full load and if its variable resistance R_{adj} is increased to 250 Ω , what is the new speed of the motor? Compare the full-load speed of the motor with $R_{\text{adj}} = 175 \ \Omega$ to the full-load speed with $R_{\text{adj}} = 250 \ \Omega$. (Assume no armature reaction, as in the previous problem.)
- 9-4. Assume that the motor is operating at full load and that the variable resistor R_{adj} is again 175 Ω . If the armature reaction is 1200 A \cdot turns at full load, what is the speed of the motor? How does it compare to the result for Problem 9-2?
- 9-5. If R_{adj} can be adjusted from 100 to 400 Ω , what are the maximum and minimum no-load speeds possible with this motor?
- 9-6. What is the starting current of this machine if it is started by connecting it directly to the power supply V_T ? How does this starting current compare to the full-load current of the motor?

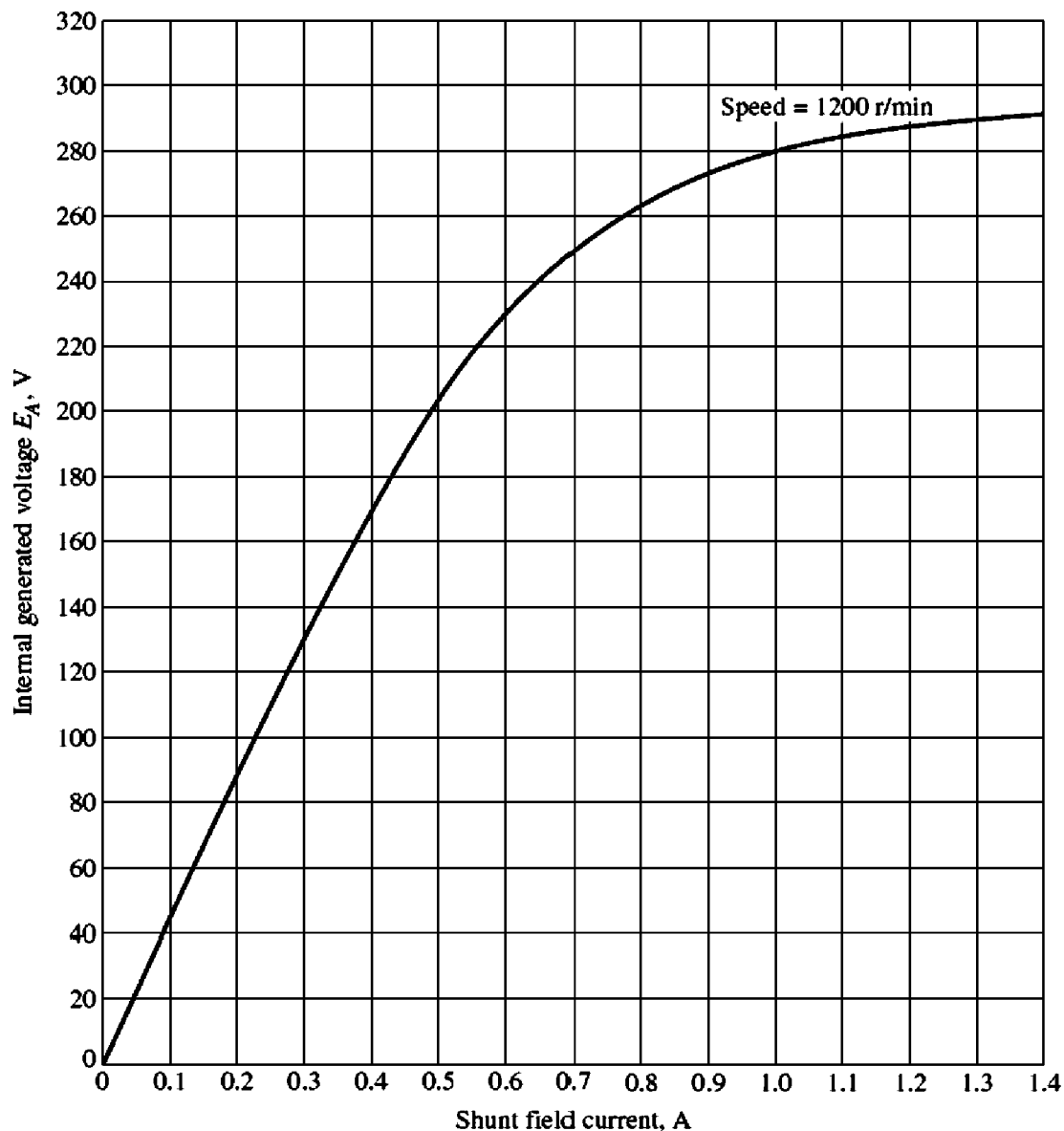
**FIGURE P9-1**

The magnetization curve for the dc motor in Problems 9-1 to 9-12. This curve was made at a constant speed of 1200 r/min.

- 9-7. Plot the torque-speed characteristic of this motor assuming no armature reaction, and again assuming a full-load armature reaction of 1200 A • turns.

For Problems 9-8 and 9-9, the shunt dc motor is reconnected separately excited, as shown in Figure P9-3. It has a fixed field voltage V_F of 240 V and an armature voltage V_A that can be varied from 120 to 240 V.

- 9-8. What is the no-load speed of this separately excited motor when $R_{adj} = 175 \Omega$ and
 (a) $V_A = 120$ V, (b) $V_A = 180$ V, (c) $V_A = 240$ V?
- 9-9. For the separately excited motor of Problem 9-8:
 (a) What is the maximum no-load speed attainable by varying both V_A and R_{adj} ?
 (b) What is the minimum no-load speed attainable by varying both V_A and R_{adj} ?

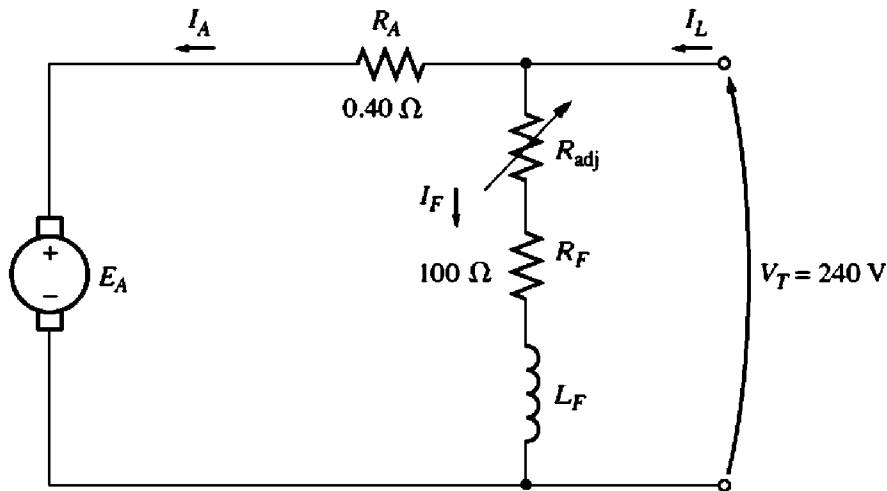
FIGURE P9-2

The equivalent circuit of the shunt motor in Problems 9-1 to 9-7.

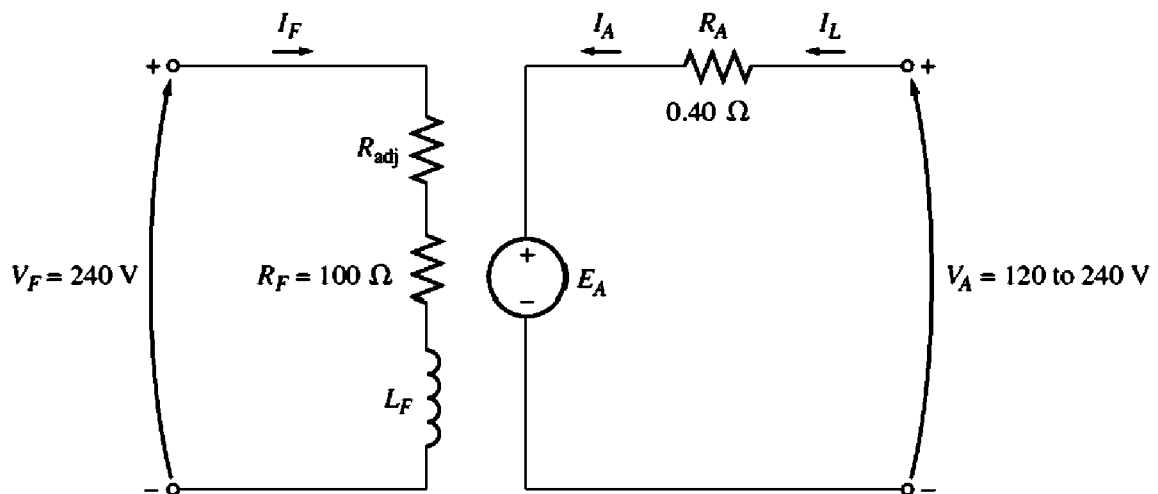
FIGURE P9-3

The equivalent circuit of the separately excited motor in Problems 9-8 and 9-9.

- 9-10. If the motor is connected cumulatively compounded as shown in Figure P9-4 and if $R_{adj} = 175 \Omega$, what is its no-load speed? What is its full-load speed? What is its speed regulation? Calculate and plot the torque-speed characteristic for this motor. (Neglect armature effects in this problem.)
- 9-11. The motor is connected cumulatively compounded and is operating at full load. What will the new speed of the motor be if R_{adj} is increased to 250Ω ? How does the new speed compare to the full-load speed calculated in Problem 9-10?
- 9-12. The motor is now connected differentially compounded.
- If $R_{adj} = 175 \Omega$, what is the no-load speed of the motor?
 - What is the motor's speed when the armature current reaches 20 A? 40 A? 60 A?
 - Calculate and plot the torque-speed characteristic curve of this motor.
- 9-13. A 7.5-hp, 120-V series dc motor has an armature resistance of 0.2Ω and a series field resistance of 0.16Ω . At full load, the current input is 58 A, and the rated speed is

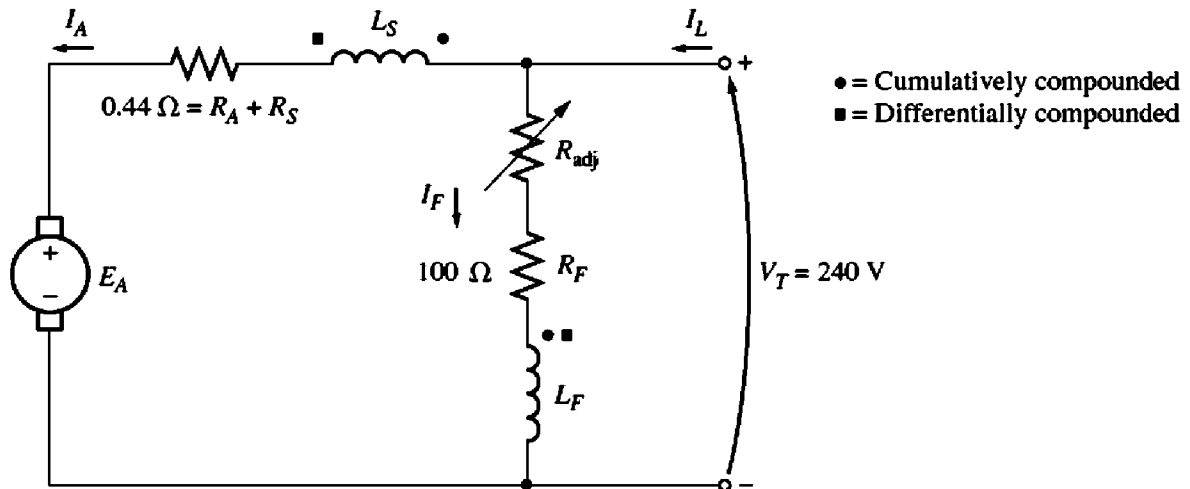

FIGURE P9-4
The equivalent circuit of the compounded motor in Problems 9-10 to 9-12.

- 1050 r/min. Its magnetization curve is shown in Figure P9-5. The core losses are 200 W, and the mechanical losses are 240 W at full load. Assume that the mechanical losses vary as the cube of the speed of the motor and that the core losses are constant.
- What is the efficiency of the motor at full load?
 - What are the speed and efficiency of the motor if it is operating at an armature current of 35 A?
 - Plot the torque-speed characteristic for this motor.
- 9-14. A 20-hp, 240-V, 76-A, 900 r/min series motor has a field winding of 33 turns per pole. Its armature resistance is 0.09 Ω, and its field resistance is 0.06 Ω. The magnetization curve expressed in terms of magnetomotive force versus E_A at 900 r/min is given by the following table:

E_A , V	95	150	188	212	229	243
\mathcal{F} , A • turns	500	1000	1500	2000	2500	3000

- Armature reaction is negligible in this machine.
- Compute the motor's torque, speed, and output power at 33, 67, 100, and 133 percent of full-load armature current. (Neglect rotational losses.)
 - Plot the torque-speed characteristic of this machine.
- 9-15. A 300-hp, 440-V, 560-A, 863 r/min shunt dc motor has been tested, and the following data were taken:

Blocked-rotor test:

$$\begin{aligned} V_A &= 16.3 \text{ V} && \text{exclusive of brushes} && V_F &= 440 \text{ V} \\ I_A &= 500 \text{ A} && && I_F &= 8.86 \text{ A} \end{aligned}$$

No-load operation:

$$\begin{aligned} V_A &= 16.3 \text{ V} && \text{including brushes} && I_F &= 8.76 \text{ A} \\ I_A &= 23.1 \text{ A} && && n &= 863 \text{ r/min} \end{aligned}$$

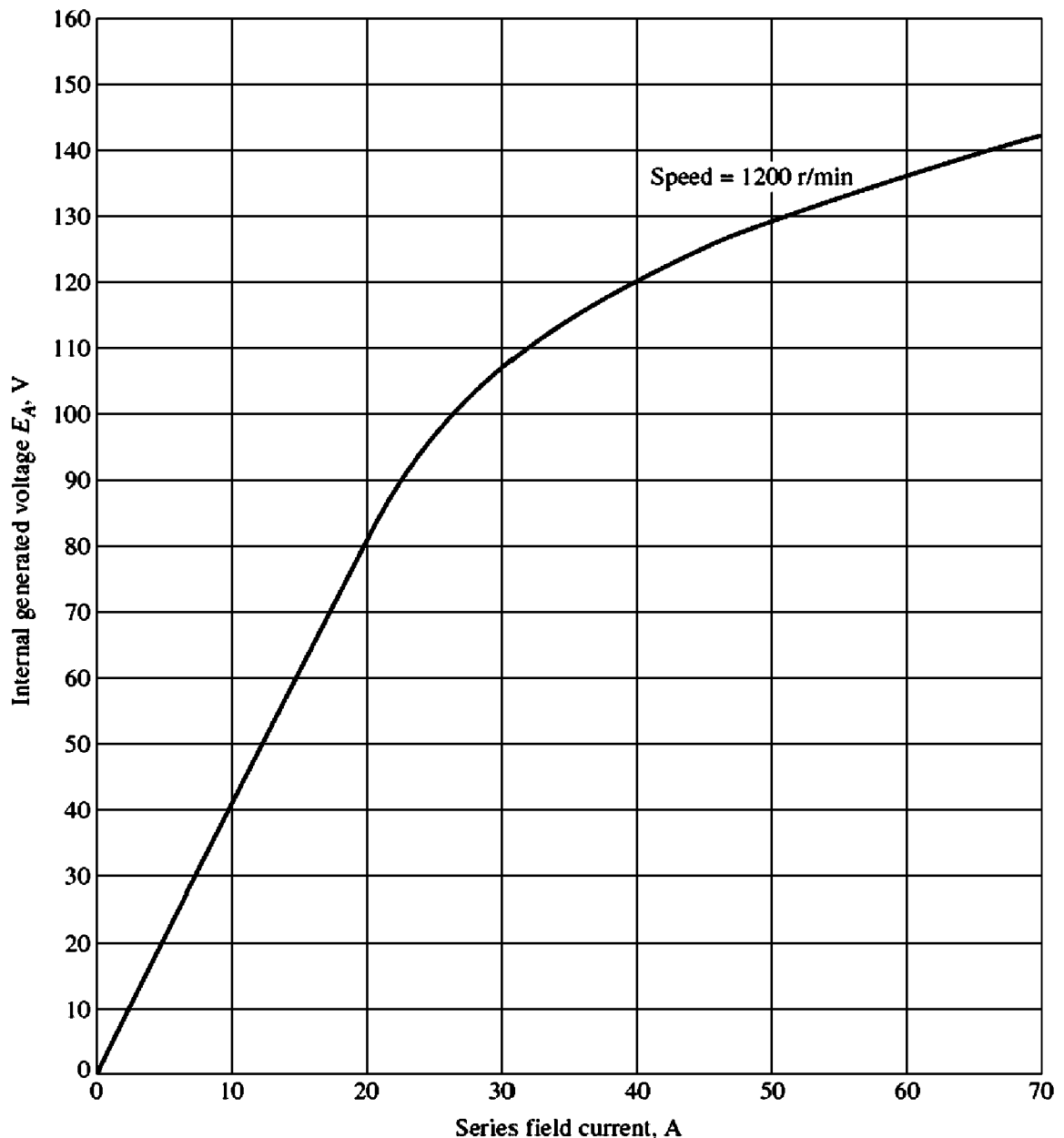
**FIGURE P9-5**

The magnetization curve for the series motor in Problem 9–13. This curve was taken at a constant speed of 1200 r/min.

What is this motor's efficiency at the rated conditions? [Note: Assume that (1) the brush voltage drop is 2 V, (2) the core loss is to be determined at an armature voltage equal to the armature voltage under full load, and (3) stray load losses are 1 percent of full load.]

Problems 9–16 to 9–19 refer to a 240-V, 100-A dc motor which has both shunt and series windings. Its characteristics are

$$R_A = 0.14 \, \Omega$$

$$N_F = 1500 \text{ turns}$$

$$R_S = 0.04 \, \Omega$$

$$N_{SE} = 12 \text{ turns}$$

$$R_F = 200 \, \Omega$$

$$n_m = 1200 \text{ r/min}$$

$$R_{adj} = 0 \text{ to } 300 \, \Omega, \text{ currently set to } 120 \, \Omega$$

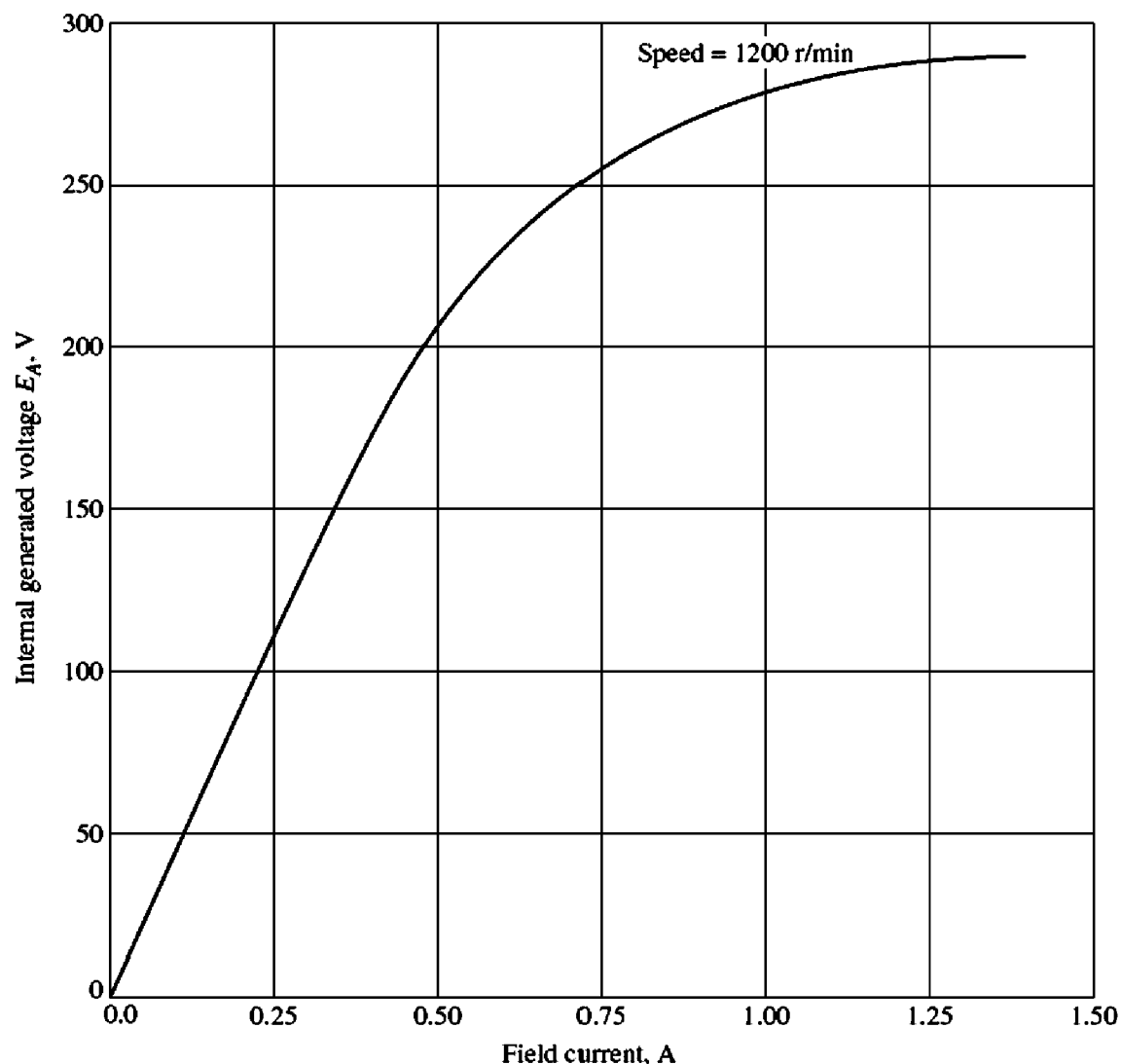

FIGURE P9-6

The magnetization curve for the dc motor in Problems 9-16 to 9-19.

This motor has compensating windings and interpoles. The magnetization curve for this motor at 1200 r/min is shown in Figure P9-6.

- 9-16. The motor described above is connected in *shunt*.
- What is the no-load speed of this motor when $R_{\text{adj}} = 120 \Omega$?
 - What is its full-load speed?
 - Under no-load conditions, what range of possible speeds can be achieved by adjusting R_{adj} ?
- 9-17. This machine is now connected as a cumulatively compounded dc motor with $R_{\text{adj}} = 120 \Omega$.
- What is the full-load speed of this motor?
 - Plot the torque-speed characteristic for this motor.
 - What is its speed regulation?
- 9-18. The motor is reconnected differentially compounded with $R_{\text{adj}} = 120 \Omega$. Derive the shape of its torque-speed characteristic.

- 9-19. A series motor is now constructed from this machine by leaving the shunt field out entirely. Derive the torque–speed characteristic of the resulting motor.
- 9-20. An automatic starter circuit is to be designed for a shunt motor rated at 15 hp, 240 V, and 60 A. The armature resistance of the motor is 0.15Ω , and the shunt field resistance is 40Ω . The motor is to start with no more than 250 percent of its rated armature current, and as soon as the current falls to rated value, a starting resistor stage is to be cut out. How many stages of starting resistance are needed, and how big should each one be?
- 9-21. A 15-hp, 230-V, 1800 r/min shunt dc motor has a full-load armature current of 60 A when operating at rated conditions. The armature resistance of the motor is $R_A = 0.15 \Omega$, and the field resistance R_F is 80Ω . The adjustable resistance in the field circuit R_{adj} may be varied over the range from 0 to 200Ω and is currently set to 90Ω . Armature reaction may be ignored in this machine. The magnetization curve for this motor, taken at a speed of 1800 r/min, is given in tabular form below:

$E_A, \text{ V}$	8.5	150	180	215	226	242
$I_F, \text{ A}$	0.00	0.80	1.00	1.28	1.44	2.88

- (a) What is the speed of this motor when it is running at the rated conditions specified above?
- (b) The output power from the motor is 7.5 hp at rated conditions. What is the output torque of the motor?
- (c) What are the copper losses and rotational losses in the motor at full load (ignore stray losses)?
- (d) What is the efficiency of the motor at full load?
- (e) If the motor is now unloaded with no changes in terminal voltage or R_{adj} , what is the no-load speed of the motor?
- (f) Suppose that the motor is running at the no-load conditions described in part e. What would happen to the motor if its field circuit were to open? Ignoring armature reaction, what would the final steady-state speed of the motor be under those conditions?
- (g) What range of no-load speeds is possible in this motor, given the range of field resistance adjustments available with R_{adj} ?
- 9-22. The magnetization curve for a separately excited dc generator is shown in Figure P9-7. The generator is rated at 6 kW, 120 V, 50 A, and 1800 r/min and is shown in Figure P9-8. Its field circuit is rated at 5 A. The following data are known about the machine:

$$\begin{aligned}
 R_A &= 0.18 \Omega & V_F &= 120 \text{ V} \\
 R_{adj} &= 0 \text{ to } 30 \Omega & R_F &= 24 \Omega \\
 N_F &= 1000 \text{ turns per pole}
 \end{aligned}$$

Answer the following questions about this generator, assuming no armature reaction.

- (a) If this generator is operating at no load, what is the range of voltage adjustments that can be achieved by changing R_{adj} ?
- (b) If the field rheostat is allowed to vary from 0 to 30Ω and the generator's speed is allowed to vary from 1500 to 2000 r/min, what are the maximum and minimum no-load voltages in the generator?

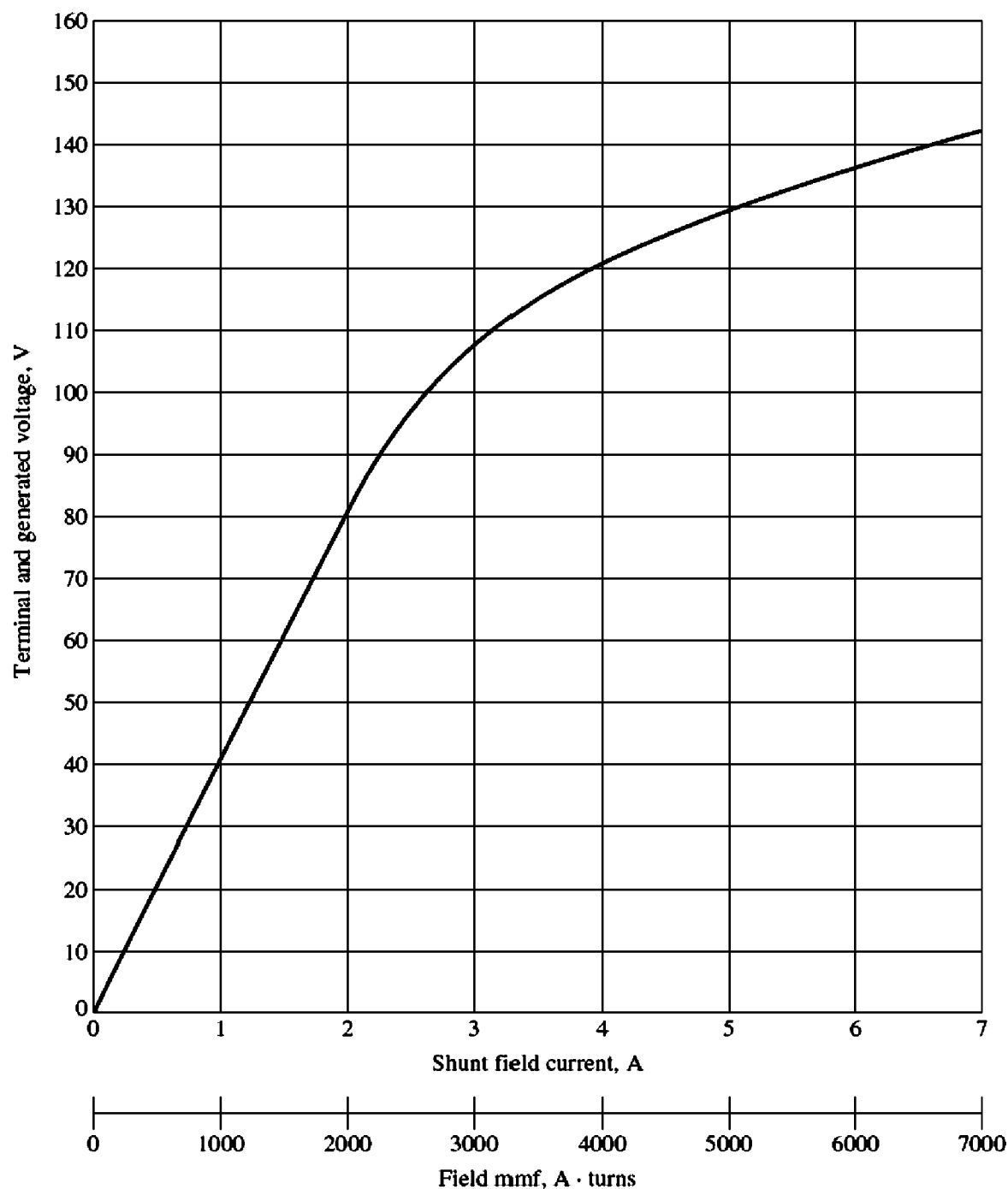

FIGURE P9-7

The magnetization curve for Problems 9-22 to 9-28. This curve was taken at a speed of 1800 r/min.

- 9-23.** If the armature current of the generator in Problem 9-22 is 50 A, the speed of the generator is 1700 r/min, and the terminal voltage is 106 V, how much field current must be flowing in the generator?
- 9-24.** Assuming that the generator in Problem 9-22 has an armature reaction at full load equivalent to 400 A · turns of magnetomotive force, what will the terminal voltage of the generator be when $I_F = 5$ A, $n_m = 1700$ r/min, and $I_A = 50$ A?
- 9-25.** The machine in Problem 9-22 is reconnected as a shunt generator and is shown in Figure P9-9. The shunt field resistor R_{adj} is adjusted to 10 Ω , and the generator's speed is 1800 r/min.

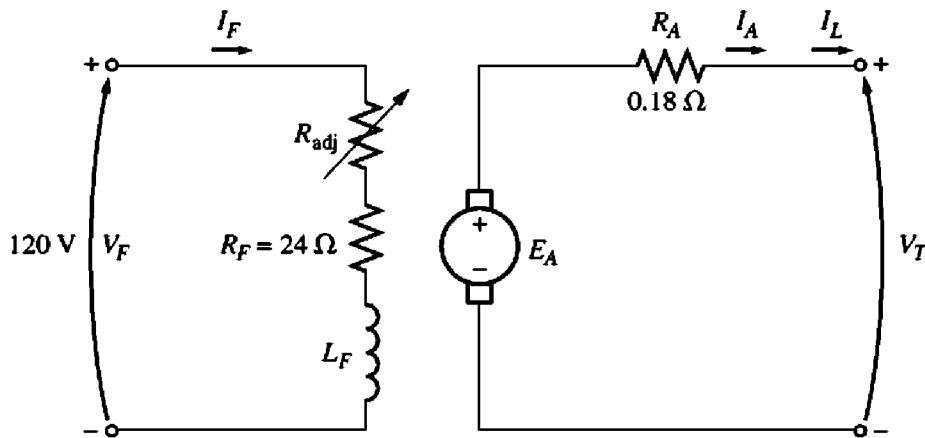

FIGURE P9-8

The separately excited dc generator in Problems 9-22 to 9-24.

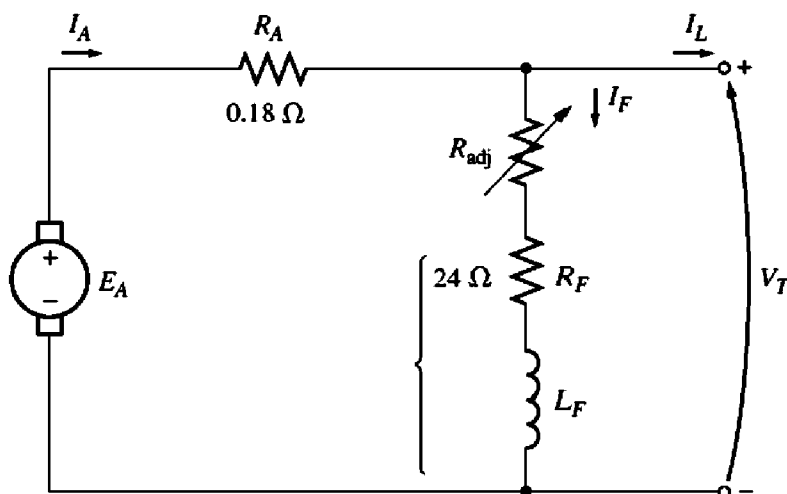

FIGURE P9-9

The shunt dc generator in Problems 9-25 and 9-26.

- What is the no-load terminal voltage of the generator?
- Assuming no armature reaction, what is the terminal voltage of the generator with an armature current of 20 A? 40 A?
- Assuming an armature reaction equal to 300 A • turns at full load, what is the terminal voltage of the generator with an armature current of 20 A? 40 A?
- Calculate and plot the terminal characteristics of this generator with and without armature reaction.

9-26. If the machine in Problem 9-25 is running at 1800 r/min with a field resistance $R_{adj} = 10 \Omega$ and an armature current of 25 A, what will the resulting terminal voltage be? If the field resistor decreases to 5 Ω while the armature current remains 25 A, what will the new terminal voltage be? (Assume no armature reaction.)

9-27. A 120-V, 50-A cumulatively compounded dc generator has the following characteristics:

$$R_A + R_S = 0.21 \Omega$$

$$R_F = 20 \Omega$$

$$R_{adj} = 0 \text{ to } 30 \Omega, \text{ set to } 10 \Omega$$

$$N_F = 1000 \text{ turns}$$

$$N_{SE} = 20 \text{ turns}$$

$$n_m = 1800 \text{ r/min}$$

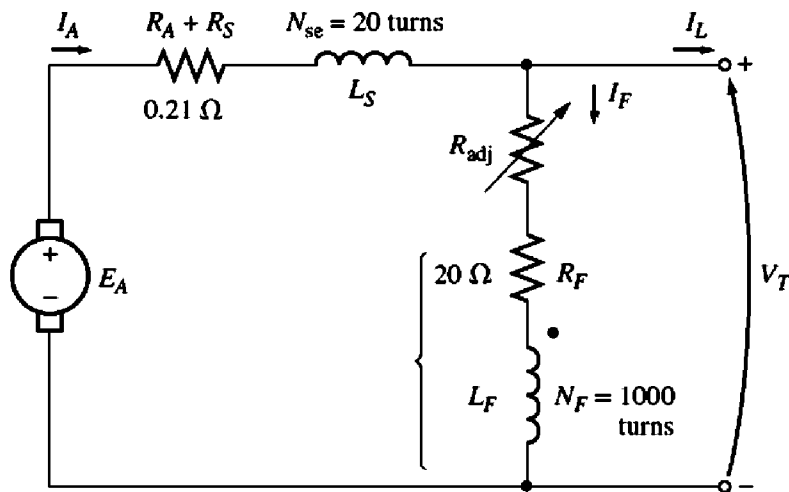

FIGURE P9-10

The compounded dc generator in Problems 9-27 and 9-28.

- The machine has the magnetization curve shown in Figure P9-7. Its equivalent circuit is shown in Figure P9-10. Answer the following questions about this machine, assuming no armature reaction.
- If the generator is operating at no load, what is its terminal voltage?
 - If the generator has an armature current of 20 A, what is its terminal voltage?
 - If the generator has an armature current of 40 A, what is its terminal voltage?
 - Calculate and plot the terminal characteristic of this machine.
- 9-28. If the machine described in Problem 9-27 is reconnected as a differentially compounded dc generator, what will its terminal characteristic look like? Derive it in the same fashion as in Problem 9-27.
- 9-29. A cumulatively compounded dc generator is operating properly as a flat-compounded dc generator. The machine is then shut down, and its shunt field connections are reversed.
- If this generator is turned in the same direction as before, will an output voltage be built up at its terminals? Why or why not?
 - Will the voltage build up for rotation in the opposite direction? Why or why not?
 - For the direction of rotation in which a voltage builds up, will the generator be cumulatively or differentially compounded?
- 9-30. A three-phase synchronous machine is mechanically connected to a shunt dc machine, forming a motor-generator set, as shown in Figure P9-11. The dc machine is connected to a dc power system supplying a constant 240 V, and the ac machine is connected to a 480-V, 60-Hz infinite bus.

The dc machine has four poles and is rated at 50 kW and 240 V. It has a per-unit armature resistance of 0.04. The ac machine has four poles and is Y-connected. It is rated at 50 kVA, 480 V, and 0.8 PF, and its saturated synchronous reactance is 2.0 Ω per phase.

All losses except the dc machine's armature resistance may be neglected in this problem. Assume that the magnetization curves of both machines are linear.

- Initially, the ac machine is supplying 50 kVA at 0.8 PF lagging to the ac power system.

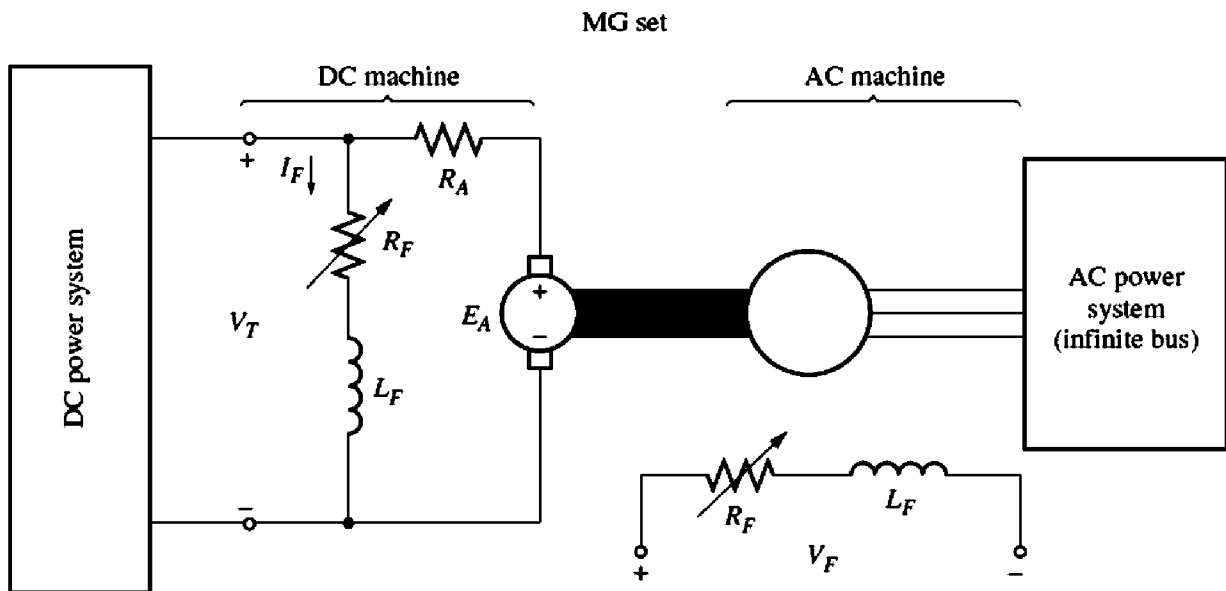

FIGURE P9-11
The motor-generator set in Problem 9-30.

1. How much power is being supplied to the dc motor from the dc power system?
 2. How large is the internal generated voltage E_A of the dc machine?
 3. How large is the internal generated voltage E_A of the ac machine?
- (b) The field current in the ac machine is now increased by 5 percent. What effect does this change have on the real power supplied by the motor-generator set? On the reactive power supplied by the motor-generator set? Calculate the real and reactive power supplied or consumed by the ac machine under these conditions. Sketch the ac machine's phasor diagram before and after the change in field current.
- (c) Starting from the conditions in part b, the field current in the dc machine is now decreased by 1 percent. What effect does this change have on the real power supplied by the motor-generator set? On the reactive power supplied by the motor-generator set? Calculate the real and reactive power supplied or consumed by the ac machine under these conditions. Sketch the ac machine's phasor diagram before and after the change in the dc machine's field current.
- (d) From the above results, answer the following questions:
1. How can the real power flow through an ac-dc motor-generator set be controlled?
 2. How can the reactive power supplied or consumed by the ac machine be controlled without affecting the real power flow?

REFERENCES

1. Chaston, A. N. *Electric Machinery*. Reston, Va.: Reston Publications, 1986.
2. Fitzgerald, A. E., and C. Kingsley, Jr. *Electric Machinery*. New York: McGraw-Hill, 1952.
3. Fitzgerald, A. E., C. Kingsley, Jr., and S. D. Umans. *Electric Machinery*, 5th ed. New York: McGraw-Hill, 1990.
4. Heck, C. *Magnetic Materials and Their Applications*. London: Butterworth & Co., 1974.

5. IEEE Standard 113-1985, *Guide on Test Procedures for DC Machines*. Piscataway, N.J.: IEEE, 1985. (Note that this standard has been officially withdrawn but is still available.)
6. Kloeffler, S. M., R. M. Kerchner, and J. L. Brenneman. *Direct Current Machinery*. Rev. ed. New York: Macmillan, 1948.
7. Kosow, Irving L. *Electric Machinery and Transformers*. Englewood Cliffs, N.J.: Prentice-Hall, 1972.
8. McPherson, George. *An Introduction to Electrical Machines and Transformers*. New York: Wiley, 1981.
9. Siskind, Charles S. *Direct-Current Machinery*. New York: McGraw-Hill, 1952.
10. Slemon, G. R., and A. Straughen. *Electric Machines*. Reading, Mass.: Addison-Wesley, 1980.
11. Werninck, E. H. (ed.). *Electric Motor Handbook*. London: McGraw-Hill, 1978.